

GCCF

PLANNED UNIT DEVELOPMENT (PUD)
BINDING MASTER PLAN

December 6, 2023

ADOPTED BY ORDINANCE NO. 2024-_____
_____, 2024

GCCF PUD

PROJECT NARRATIVE

The GCCF PUD was originally a 300 +/- acre property located south of Laurel Road, north of Border Road, east of I-75 and the City's wastewater treatment plant, and west of the Milano PUD. The property is located within the Northeast Neighborhood of the City's Comprehensive Plan and is designated Mixed Use Residential on the Future Land Use Map.

Ordinance No. 2019-19 approved the GCCF PUD for the development of a residential community consisting of detached single-family homes, paired villas, multi-family homes, assisted living facilities, amenity centers, and open space. A 25 +/- acre portion of the property was approved for House of Worship as permitted use, and Medical Office as a Special Exception Use, as an alternative to residential.

Access to the site is via Laurel Road and Border Road. Consistent with Comprehensive Plan Strategy TR-NE 1.1.4 a north/south roadway connection between Laurel Road and Border Road is required through the GCCF PUD. In addition, where common ownership with the Milano PUD to the east exists, one or more optional interconnections between the properties is permitted. The circulation plan for the GCCF PUD provides opportunities for multi-modal connectivity, and includes a linked sidewalk system for pedestrian connectivity from each of the development pods throughout the PUD. Further, sidewalk linkages along Laurel Road and Border Road are provided to the project limit.

All internal roadways will be privately owned and maintained. The on-site storm water management system will be privately owned and maintained. Water and wastewater facilities will be dedicated to the City of Venice or Sarasota County as applicable.

The PUD was previously amended by Ordinance No. 2022-20 to add 24.1 acres of open space along the eastern boundary of the PUD relocated from the adjacent Milano PUD and to modify the lot standard detail to clarify yards standards for lots with alleys. In addition, minor revisions to the approved PUD plan were approved which incorporated previously approved preliminary plat approvals regarding location of open space, stormwater ponds, internal roadways and the amenity area, the addition of a sidewalk segment on the east side of the spine road, the elimination of a "potential access point" along Border Road, and the elimination of the multi-family use for lots south of the east-west FPL easement. No other changes were proposed to the approved uses or development standards.

This amendment to the PUD increased the currently approved density from 1,300 dwelling units (4.3 units per acre) to 1,617 dwelling units (5.0 units per acre). There were no other changes to the currently approved GCCF Binding Master Plan.

COMPLIANCE

The proposed GCCF PUD plan is consistent with all applicable elements of the City's Comprehensive Plan. Specifically, the proposed GCCF PUD is consistent with the Northeast Neighborhood plan and the existing and future land uses therein, including Strategy LU-NE 1.1.1. which designates the property Mixed Use Residential (MUR) and allows for up to five (5) dwelling units per acre.

Pursuant to Comprehensive Plan Strategy LU- NE 1.1.1. C LU-1.2.16.6.c a minimum of 50% open space will be provided including a minimum of 10% Functional and 10% Conservation Open Space.

As noted above, consistent with Strategy TR-NE 1.1.4 a north/south roadway connection between Laurel Road and Border Road will be provided through the GCCF PUD.

In addition, the GCCF PUD plan is in compliance with the applicable Intents and Strategies of the Transportation, Open Space, Housing, Infrastructure, and Public Schools Elements of the Comprehensive Plan.

Finally, the proposed GCCF PUD is in compliance with the City of Venice Land Development Code Sec. 86-130 requirements for Planned Unit Development (PUD) Districts as outlined in the below Land Use and Development Standards.

LAND USE AND DEVELOPMENT STANDARDS

The following identifies the proposed development standards for the GCCF Planned Unit Development. In furtherance of the interpretation authority granted by the City of Venice Comprehensive Plan and Land Development Code, the Zoning Administrator shall have authority to administratively approve minor modifications of standards contained with the GCCF Planned Unit Development, excluding standards related to density, building height, buffer widths, and the addition of uses. Reasonable mitigation measures may be imposed by the Zoning Administrator to limit impacts from the requested adjustment of standards. Where the PUD master plan identifies areas for residential uses, the developer shall have the option to convert such residential use areas to open space uses.

Any standard not stated or otherwise addressed in the binding master plan is subject to Chapter 86- Land Development Code.

A. Land Uses

1) Permitted Principal Uses and Structures

- Residential single-family dwellings (detached)
- Residential single-family dwellings (attached)
- Multi-family dwellings
- Private club, community centers and civic and social organization facilities
- House of Worship
- Recreational areas
- Open Space
- Cell Tower

2) Permitted Accessory Uses and Structures

- Are customarily accessory and clearly incidental and subordinate to permitted or permissible uses and structures.
- Are located on the same lot as the permitted or permissible use or structure or on a contiguous lot in the same ownership.
- Do not involve operations or structures not in keeping with the character of the district.
- Do not involve the conduct of business on residential premises, provided that accessory home occupations shall be allowed as accessory to residential uses.

3) Special Exception Uses

- Assisted Living Facilities
- Medical Office

B. Density/ Intensity

- 1) Residential- Up to 1,617 residential units
- 2) Open Space- Minimum 50%
- 3) Non-Residential - Maximum FAR 0.5 (individual site)

C. Maximum Height of Structures

- 1) Single-Family - 3 stories up to 35' including parking.
- 2) Assisted Living, House of Worship, Medical Office- 5 stories up to 55' including parking. (For heights above 3 stories and 35', Conditional Use approval required)

D. LOT DETAIL

1) Single-Family Detached

- Minimum Lot Size: 4,500 square feet
- Maximum Lot Coverage: None, except as required to meet other requirements set out in this section
- Minimum Lot Width: 40 feet
- Front Yard: 20 feet
- Side Yard: 5 feet
- Rear Yard: 10 feet
- Accessory structures/appurtenant structures including, but not limited to pool cages, may be located within five feet of the rear lot line

2) Single-Family Attached (Paired Villas)

- Minimum Lot Size: 4,025 square feet
- Maximum Lot Coverage: None, except as required to meet other requirements set out in this section
- Minimum Lot Width: 35 feet
- Front Yard: 20 feet
- Side Yard: 5 feet
- Rear Yard: 10 feet
- Accessory structures/appurtenant structures including, but not limited to pool cages, may be located within five feet of the rear lot line

3) Multi-Family

- Minimum Lot Size: 7,200 square feet
- Maximum Lot Coverage: None, except as required to meet other requirements as set out in this section
- Minimum Lot Width: 90 feet
- Front Yard: 20 feet
- Side Yard: 5 feet
- Rear Yard: 10 feet
- Accessory structures/appurtenant structures including, but not limited to pool cages, may be located within five feet of the rear lot li

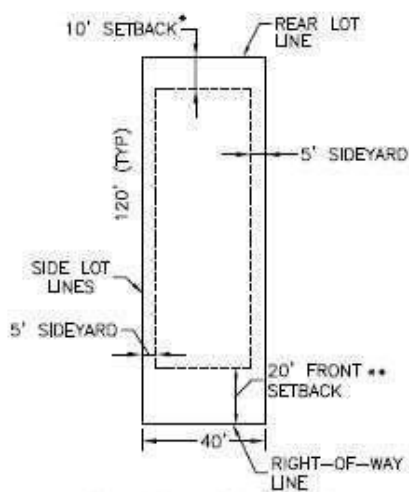

TYPICAL LOT DETAIL
SINGLE FAMILY DETACHED

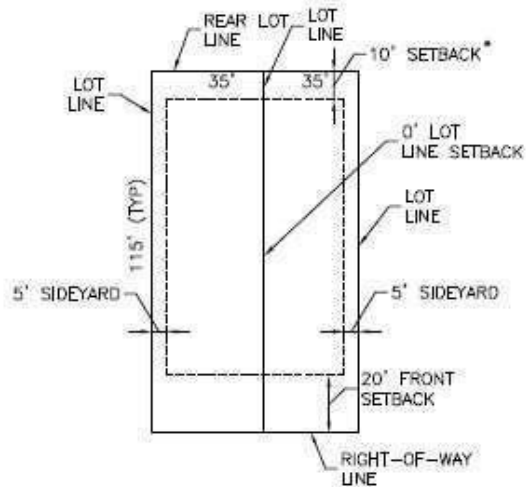

TYPICAL LOT DETAIL
PAIRED VILLAS

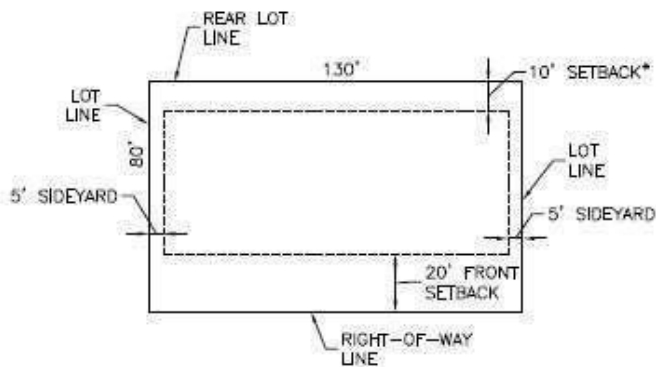

MULTI-FAMILY LOT DETAIL
4 PLEX / 6 PLEX

*** REAR YARD STANDARDS SHALL APPLY FOR YARDS ADJACENT TO ALLEYS

*** Garages attached to a primary residential structure by a breezeway shall be considered accessory structures.

• ACCESSORY STRUCTURES/APPURTENANT STRUCTURES SUCH AS POOL CAGES, MAY BE LOCATED WITHIN FIVE FEET OF THE REAR LOT LINE.

** FRONT SETBACK MAY BE REDUCED TO 15' WHEN THE BUILDING HAS A SIDE ENTRY GARAGE OR AN ALLEY LOADED GARAGE

LOT DETAILS

PROJECT: GCCF PROPERTY

CLIENT: BORDER ROAD INVESTMENT, LLC



Stantec

6900 Professional Parkway East, Sarasota, FL 34240-6414
Phone 941-407-6900 • Fax 941-407-6910
Certificate of Authorization #27013 • www.stantec.com

The Contractor shall verify and be responsible for all dimensions. DO NOT make the drawing. Any errors or omissions shall be reported to Stantec without delay. The Copyright to all designs and drawings are the property of Stantec. Reproduction or use for any purpose other than that authorized by Stantec is prohibited.

MELANIE DELEHANTY SMITH, P.E.
FLORIDA LICENSE NO. 75447

SCALE	1" = 50'	DATE	09/2018
SHEET	35/36	TWP	38S
		R&E	19E
PROJECT NO.	215614685	INDEX NO.	215614685-001-EX203
DRAWN BY/DATE NO.	RSB/115155	SHEET NO.	1 of 2

4) Assisted Living, House of Worship, Medical Office

- Minimum Lot Size: None, except as needed to meet all other requirements set out in this section.
- Maximum Lot Coverage: None, except as required to meet other requirements set out in this section
- Lot Width: 100 feet
- Front Yard: 20 feet
- Side Yard: Six feet minimum, but in no case less than 15 feet combined side yards.
- Rear Yard: 10 feet
- Accessory structure/ appurtenant structures: 5 feet
- Buildings above 35 feet shall provide additional side and rear yards at a ratio of one foot of yard for each three feet of building height above 35 feet and a front yard of 25 feet or one-half of the building height, whichever is greater.

E. BUFFERS/ LANDSCAPING

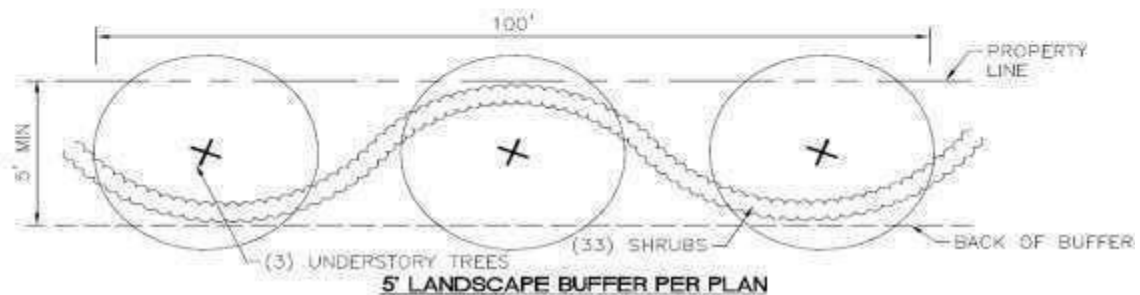
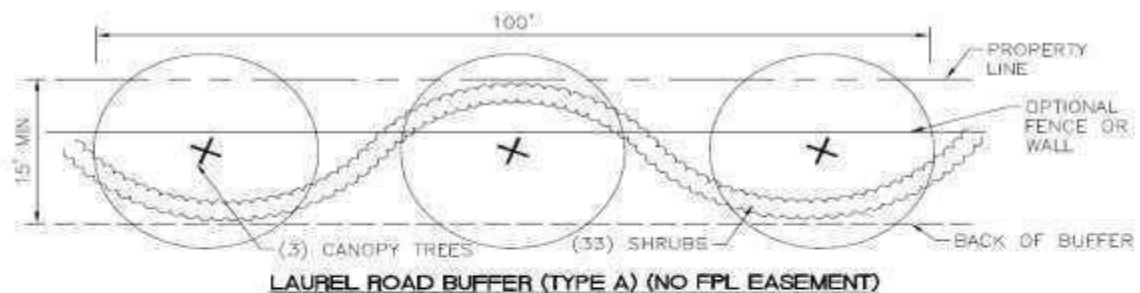

NOTES:

1. EXISTING VEGETATION TO REMAIN WHERE FEASIBLE TO SATISFY BUFFER PLANTING REQUIREMENTS.
2. TYPICAL BUFFER REQUIREMENTS WILL NOT APPLY WHERE EXISTING WETLANDS ARE TO REMAIN.
3. WHERE OVERHEAD UTILITY POLE LOCATIONS RESTRICT VERTICAL VEGETATION HEIGHTS, ACCENT TREES AS DEFINED BY SARASOTA COUNTY SHALL BE USED IN LIEU OF A CANOPY TREE.
4. BERM HEIGHTS SHALL BE LIMITED TO A RANGE 0' TO 6'.

F. Roadway Design (Minimum Design Standards)

1) The GCCF PUD proposes the following minimum roadway design for the connection road from Laurel Road to Border Road required pursuant to Comprehensive Plan Strategy TR-NE 1.1.4. (see typical connection roadway standard below)

- Right-of-Way: 52 feet
- Travel Lanes: 10 feet
- Sidewalk: 5 feet (x2)
- Bike Lane 4 feet (x 2)
- 2 foot curb
- One (1) tree per lot which may be placed within or adjacent to the ROW, minimum 3" caliper at installation

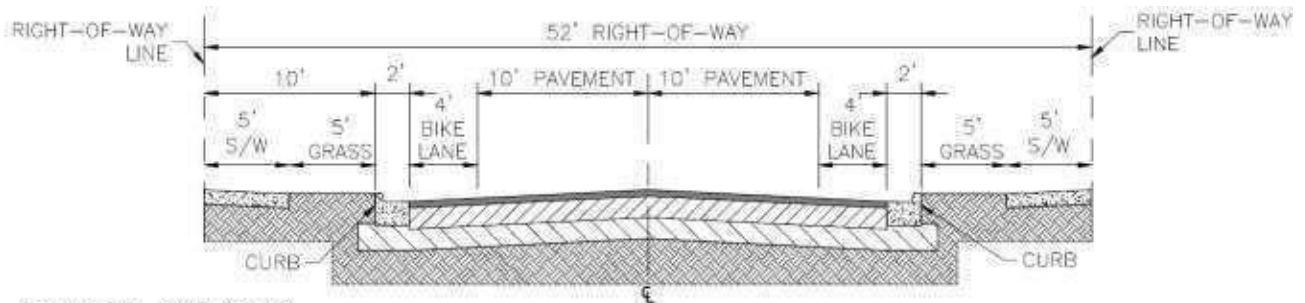

CONNECTOR ROAD NOTES:

1. THE TWO 5' SIDEWALKS CAN BE SUBSTITUTED FOR ONE 8' MURT. THE 8' MURT MAY BE PLACED ON EITHER SIDE OF THE ROAD AND THE REMAINDER OF THE COMPONENTS OF THE SECTION CAN BE SHIFTED TO MAINTAIN THE 52' MINIMUM CROSS SECTION.
2. ON STREET PARKING MAY BE ADDED TO THE SECTION SUCH THAT THE 52' MINIMUM R-O-W IS INCREASED TO ACCOMMODATE THE SPACE NEEDED FOR THE ADDITIONAL PARKING.

TYPICAL CONNECTION ROADWAY SECTION (SECTION A-A)

2) The GCCF PUD proposes an alternative minimum neighborhood roadway design with the following standards (see typical neighborhood roadway section below):

- Right-of-Way: 43 feet
- Travel Lanes: 10 feet
- Sidewalk: 5 feet, one side of street only
- 2 foot curb
- One (1) tree per lot which may be placed within or adjacent to the ROW, minimum 3" caliper at installation

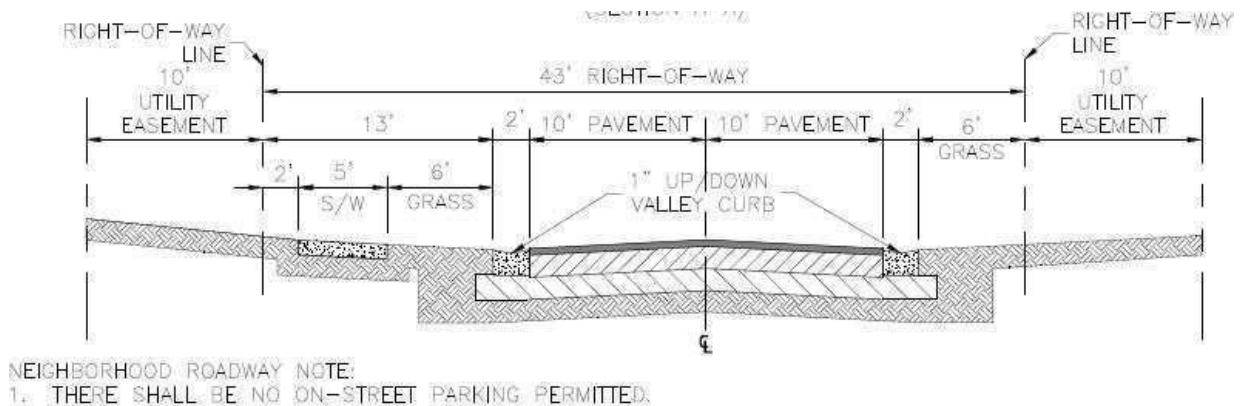

TYPICAL NEIGHBORHOOD ROADWAY SECTION
(SECTION B-B)

3) The GCCF PUD proposes an alley design with the following minimum standards (see typical alley section below):

- Right-of-Way: 20 feet

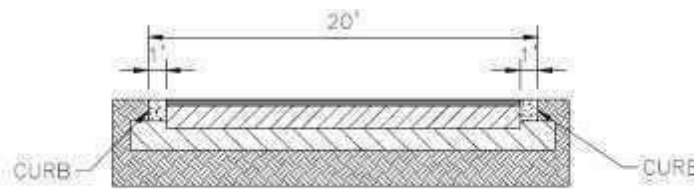

TYPICAL ALLEY SECTION
(SECTION C-C)

4) Pursuant to Sec. 86-233(3) City Council Approval of dead-end streets (cul-de-sacs) up to 1,200 feet in length is requested.

G. SIGNAGE: No signs are permitted in the GCCF PUD except:

- 1) One non-illuminated temporary construction project ground sign per street frontage, not exceeding 32 square feet in area, such sign not to be erected more than 60 days prior to the time actual construction begins, and to be removed upon completion of actual construction. If construction is not begun within 60 days or if construction is not continuously and actively prosecuted to completion, the sign shall be removed.
- 2) One community identification, monument-style ground sign, or wall sign not to exceed nine (9) feet in height and twenty (20) feet in width, on each side, or in the median and one side, of each vehicular access point off Border Road and Laurel Road.
- 3) One wall or monument-style ground sign, or wall sign not over eight square feet in area, to identify a private club.
- 4) Assisted Living Facility, Medical Office, House of Worship Signage- One monument-style ground sign, or wall sign for each lot or parcel, not over 75 square feet in area.

PROPOSED GCCF PUD MODIFICATION TO STANDARDS

- 1) A modification to the requirements of Sec. 86-130 (q), concerning the requirement that no structure, including pool cages, shall be located closer to any perimeter property line than two times the height of such structure, is requested. The proposed modification is to reduce the required setback from perimeter property lines to one times the building height.

The proposed modification request is justified based upon the low intensity of the development plan, the extensive perimeter buffers and the significant amount of open space otherwise provided.

- 2) A modification to the requirements of Sec 86-232(5) concerning the roadway design standards is proposed and an alternative neighborhood roadway design is proposed. The proposed modification reduces right-of way width from 52' to 43', allows for sidewalks on one side of the neighborhood roadway only, and eliminates bike lanes for the neighborhood roadways.

The proposed modification request is justified based upon the protection of wetlands and their buffers afforded by the modification, and the low intensity of the development plan.

- 3) A modification to the requirements of Sec 87- 3.18.B.2.a to reduce the minimum required separation of a residential driveway from the intersection of the edge of pavement of two streets from 40 feet to 30 feet.

The proposed modification is justified based upon the currently approved 40 foot lot widths in the PUD which make provision of a 40 foot driveway separation for reasonably sized driveways impossible for the limited number of lots located at the intersection of two streets.

PLANNED UNIT DEVELOPMENT PLANS FOR

GCCF PROPERTY

PART OF SECTIONS 35 & 36, TOWNSHIP 38 SOUTH, RANGE 19 EAST
 CITY OF VENICE
 SARASOTA COUNTY, FL

A DEVELOPMENT BY BORDER ROAD INVESTMENTS, LLC
 5800 LAKEWOOD RANCH BOULEVARD
 SARASOTA, FL 34240
 (941) 328-1111



INDEX TO SHEETS

SHEET NO.	DESCRIPTION
1	COVER SHEET
2	MASTER SITE AND CIRCULATION PLAN

Civil Engineering | Land Surveying | 8340 Consumer Court Sarasota, FL 34240 | Phone: (941) 377-9178 | www.amengfl.com | CA #33105 | LB #4334

REV. No.	REV. DATE	REVISION DESCRIPTION	BY
2	05/17/22	RESPONSE TO CITY COMMENTS	BRC
1	03/30/22	RESPONSE TO CITY COMMENTS	BRC

CALL BEFORE YOU DIG!
 "SUNSHINE STATE ONE-CALL CENTER"
 1-800-432-4770
 THE CONTRACTOR SHALL NOTIFY "SUNSHINE STATE ONE-CALL CENTER" AND ALL OTHER UTILITIES FOR LOCATION OF EXISTING FACILITIES PRIOR TO BEGINNING CONSTRUCTION.

ISSUE DATE: **JANUARY 27, 2022** BRC

ISSUE DESCRIPTION: **PUD MODIFICATION**

Civil Engineering | Land Surveying

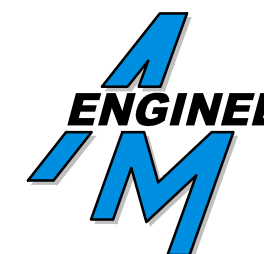

AM ENGINEERING, LLC.

8340 Consumer Court Sarasota, FL 34240
 Phone: (941) 377-9178 | www.amengfl.com
 CA #33105 | LB #4334

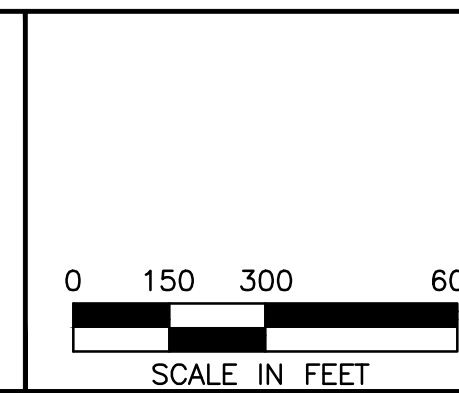

CLIENT:	BORDER ROAD INVESTMENTS, LLC
PROJECT:	GCCF PROPERTY
TITLE:	COVER SHEET

HORIZONTAL SCALE:	1" = 300'
VERTICAL SCALE:	N/A
VERTICAL DATE:	N/A
PROJECT NUMBER:	NEAL0016PUD
SHEET NUMBER:	1

PROJECT ENGINEER:

BOBBI R. CLAYBROOKE, PE
 DATE: _____
 FLORIDA P.E. No. 90804

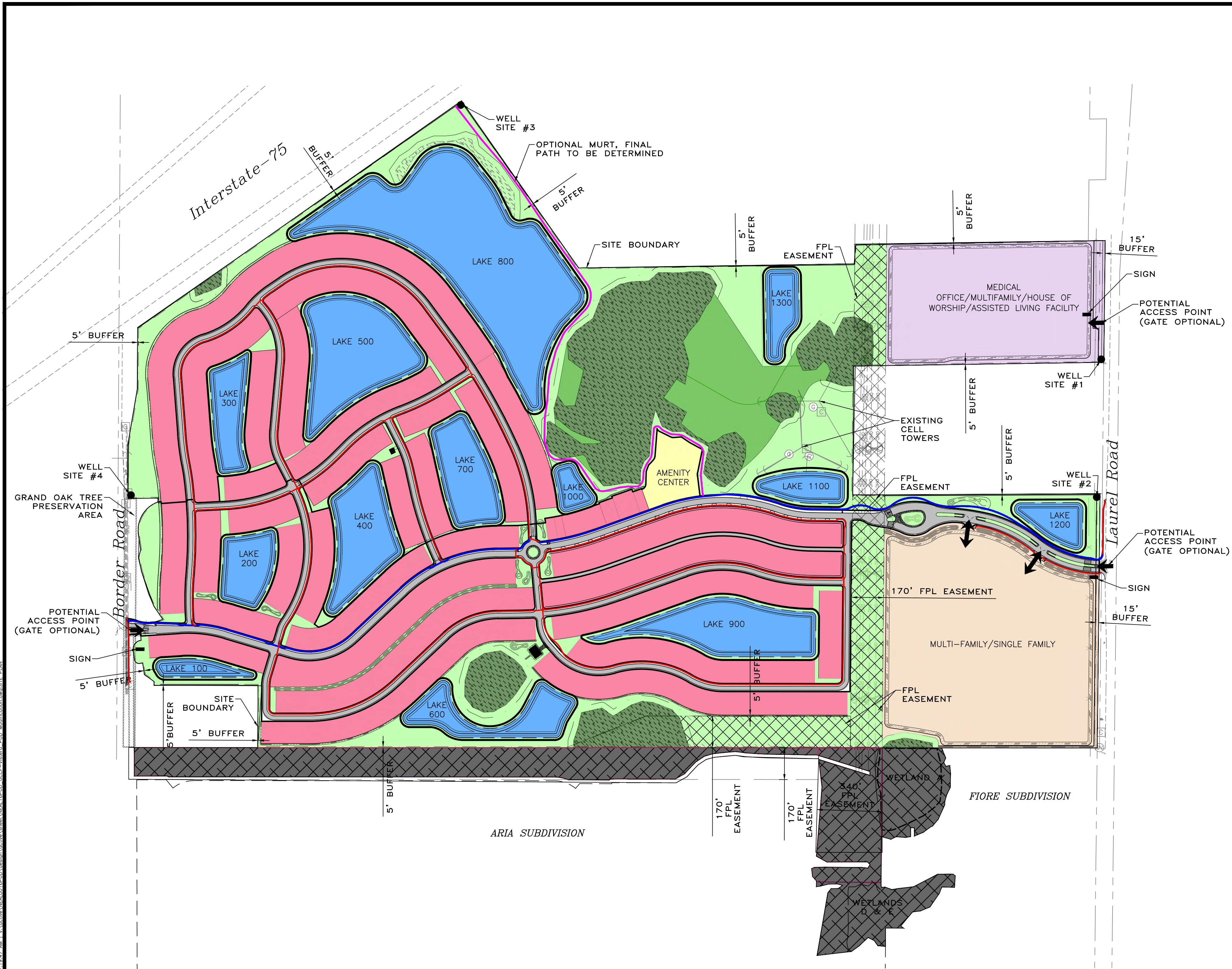

LAND USE AREA TABLE

LAND USE	AREA AS SHOWN (AC)	% AS SHOWN	REQUIRED AREA (AC)	REQUIRED %
SINGLE FAMILY RESIDENTIAL	89.01	27.5		
AMENITY AREA	2.10	0.6		
MULTI-FAMILY/SINGLE FAMILY	28.64	8.9		
MEDICAL OFFICE/MULTIFAMILY/HOUSE OF WORSHIP/ASSISTED LIVING FACILITY	17.46	5.4		
R.O.W.	23.95	7.4		
OPEN SPACE	45.94	14.2		
MITIGATION AREA	8.44	2.6		
EXISTING WETLAND	22.49	7.0		
EXISTING LAKES/PROPOSED LAKES	50.96	15.8		
OTHER OPEN SPACES	10.47	3.2		
OPEN SPACE FROM MILANO PUD	24.10	7.4		
OPEN SPACE TOTAL	162.40	50.2	161.78	50.0
TOTAL AREA	323.56	100.0		

- PROPOSED 5' SIDEWALKS
- PROPOSED 8' MULTI-USE RECREATIONAL TRAIL (MURT)
- PROPOSED 8' OPTIONAL MULTI-USE RECREATIONAL TRAIL (MURT), FINAL PATH TO BE DETERMINED

- NOTES:**
- WELL SITES TO BE RELOCATED SUBJECT TO MUTUAL AGREEMENT BETWEEN OWNER AND CITY.
 - ENTRY GATES TO BE OPENED DURING EMERGENCY AS DETERMINED BY VENICE POLICE AND FIRE DEPARTMENTS.
 - THE SIDEWALKS SHOWN ARE CONCEPTUAL AND MAY BE LOCATED ON THE OTHER SIDE OF THE ROAD.

REV. No.	REV. DATE	REVISION DESCRIPTION	BY
2	05/17/22	RESPONSE TO CITY COMMENTS	BRC
1	03/30/22	RESPONSE TO CITY COMMENTS	BRC

CALL BEFORE YOU DIG!
 "SUNSHINE STATE ONE-CALL CENTER"
 1-800-432-4770
 THE CONTRACTOR SHALL NOTIFY "SUNSHINE STATE ONE-CALL CENTER" AND ALL OTHER UTILITIES FOR LOCATION OF EXISTING FACILITIES PRIOR TO BEGINNING CONSTRUCTION.

ISSUE DATE: **JANUARY 27, 2022** ISSUED BY: **BRC**

PUD MODIFICATION

Civil Engineering | Land Surveying

AM ENGINEERING, LLC.

8340 Consumer Court Sarasota, FL 34240
 Phone: (941) 377-9178 | www.amengfl.com
 CA #33105 | LB #4334

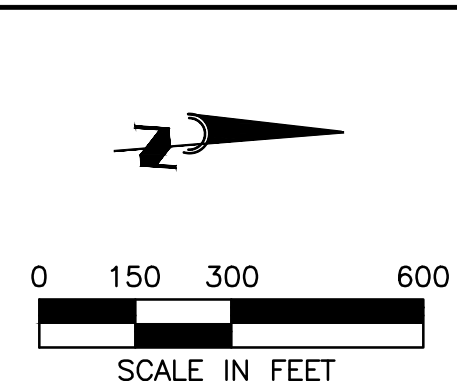

BORDER ROAD INVESTMENTS, LLC

GCCF PROPERTY

MASTER SITE & CIRCULATION PLAN

HORIZONTAL SCALE	1" = 300'
VERTICAL SCALE	N/A
VERTICAL DATUM	N/A
PROJECT NUMBER	NEAL0016PUD
SHEET NUMBER	2

PROJECT ENGINEER:
BOBBI R. CLAYBROOKE, PE
 DATE _____
 FLORIDA P.E. No. 90804