

BOTANICS DESIGN GROUP, LLC
 3027 Via San Marco Court
 Fort Myers, FL 33905
 BUS. LIC # LC26000503
 WWW.BOTANICSDSIGNGROUP.COM
 PH: 239-639-7151
 EMAIL: JOSH@BOTANICSDSIGNGROUP.COM

SIGN AND SEALED BY:
 REG. LA # 01750
 JOSEPH KELLEY, RLA

REVISIONS	
DATE	DESCRIPTION

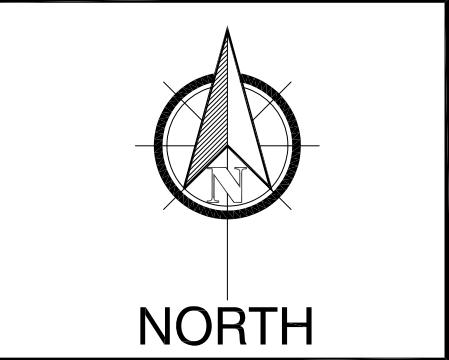

CLIENT NAME:
 TOSCANA ISLES
 COMMUNITY DEVELOPMENT
 DISTRICT

TOSCANA ISLES
 TYPICAL TYPE A BUFFER PLAN
 CITY OF VENICE, FLORIDA

LA-1
 1 of 6
 DATE: 09/07/2018
 DRAWN BY: JHK

BUFFER A: TYPICAL 100' SECTION

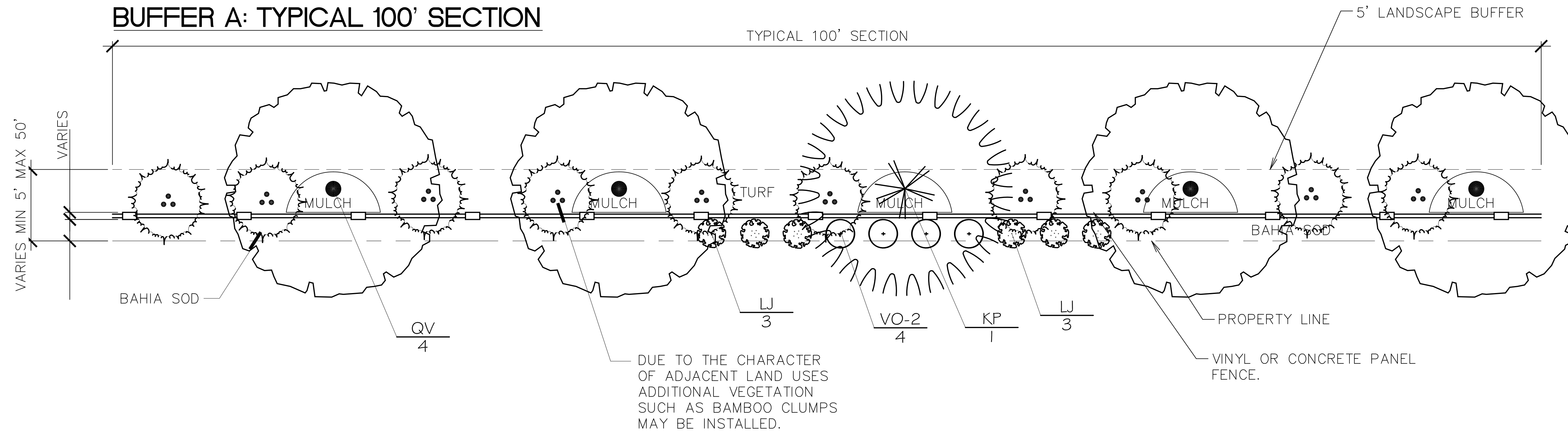

PLANT_SCHEDULE

TREES	BOTANICAL NAME	COMMON NAME	CONT	CAL	H	QTY
KP	Koelreutena paniculata Full dense foliage, nice character	Golden Rain Tree	25 gallon min.	3" minimum		1
QV	Quercus virginiana Full dense symmetrical canopy, straight unscarred trunk	Southern Live Oak	25 gallon min.	3" minimum		4
SHRUBS	BOTANICAL NAME	COMMON NAME	CONT	H	W	QTY
LJ	Ligustrum japonicum Full, dense foliage to base, dark green	Japanese Privet	3 gal	24"	24"	6
VO-2	Viburnum odoratissimum `Awabuki` Full, dense foliage to base	Viburnum Awabuki	3 gal	24"	24"	4

PLEASE NOTE:

FOR EACH 100' SECTION OF BUFFER ALTERNATE BETWEEN SOUTHERN MAGNOLIA AND GOLDEN RAIN TREE.

PLANT_SCHEDULE_BUFFER_A_ALTERNATE

TREES	BOTANICAL NAME	COMMON NAME	CONT	CAL	H	QTY
MG	Magnolia grandiflora Full dense canopy, nice character	Southern Magnolia	25 gallon min.	3" minimum		1
QV	Quercus virginiana Full dense symmetrical canopy, straight unscarred trunk	Southern Live Oak	25 gallon min.	3" minimum		4
SHRUBS	BOTANICAL NAME	COMMON NAME	CONT	H	W	QTY
LJ	Ligustrum japonicum Full, dense foliage to base, dark green	Japanese Privet	3 gal	24"	24"	6
VO-2	Viburnum odoratissimum `Awabuki` Full, dense foliage to base	Viburnum Awabuki	3 gal	24"	24"	4

PLEASE NOTE:

BUFFER A:

- FOR EACH 10' OF FENCE, AN AVERAGE OF ONE SHRUB OR VINE SHOULD BE PLANTED ABUTTING SUCH FENCE, BUT THESE NEED NOT BE SPACED 10' APART.

- SHRUBS OR VINES SHALL BE PLANTED ALONG THE PROPERTY LINE SIDE OF SUCH FENCE, UNLESS THEY ARE OF SUFFICIENT HEIGHT AT THE TIME OF PLANTING TO BE READILY VISIBLE OVER THE TOP OF SUCH FENCE.

- THE REMAINDER OF THE REQUIRED LANDSCAPE AREAS SHALL BE LANDSCAPED WITH GRASS, GROUND COVER OR OTHER LANDSCAPE TREATMENT.

- THE FENCE SHALL BE SO LOCATED WITHIN THE LANDSCAPED BUFFER AREA AS TO PERMIT MAINTENANCE WITHOUT TRESPASS ON ADJACENT PROPERTY.

- PEDESTRIAN AND VEHICULAR INTERCONNECTIONS TO ADJOINING PUBLIC AND PRIVATE ROADWAYS AND PROPERTIES SHALL BE PERMITTED.

- ALL BUFFER AREAS SHALL BE COVERED BY GRASS, VEGETATIVE GROUND COVERINGS, OR MULCH IN AREAS NOT UTILIZED FOR TREE AND SHRUB PLANTINGS AND INCLUDE AT LEAST ONE CANOPY TREE FOR EACH 20 LINEAL FEET OF BUFFER. TREES SHALL HAVE A TRUNK DIAMETER OF AT LEAST 3" (MEASURED AT 6" ABOVE THE GROUND) AND BE A MINIMUM OF 25 GALLON CONTAINER SIZE OR HAVE A MINIMUM 2' DIAMETER ROOT BALL, IF FIELD GROWN. TREES SHALL BE FLORIDA #1 OR BETTER QUALITY AS PER GRADES AND STANDARDS FOR NURSERY PLANTS (FLORIDA DEPARTMENT OF AGRICULTURE AND CONSUMER SERVICES.)

- APPLICANT MAY SUBSTITUTE ALTERNATE SPECIES OF TREES AND SHRUBS BASED ON MATERIAL SELECTIONS AND AVAILABILITY AT TIME OF PLANTING.

- APPLICANT AT IT'S DISCRETION, MAY INSTALL ADDITIONAL/ENHANCED BUFFER LANDSCAPING BEYOND THE MINIMUM SHOWN ON THIS PLAN.

- BUFFER MAY BE PLANTED ON BERM.

BUFFER A: TYPICAL 100' SECTION - ELEVATION

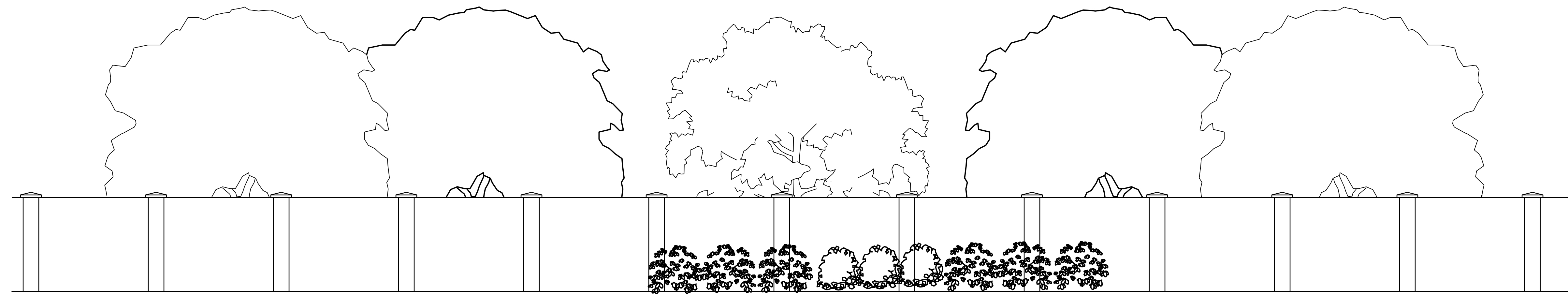

BUFFER A: SECTION

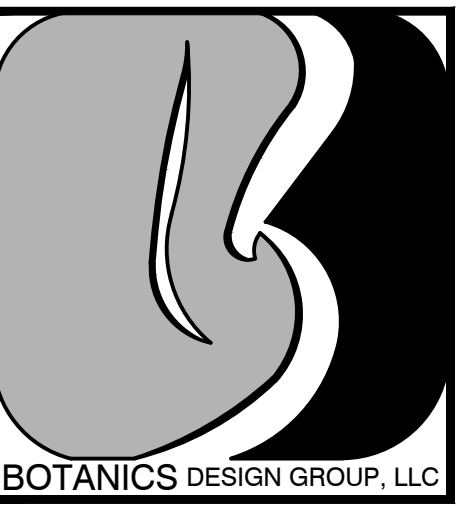
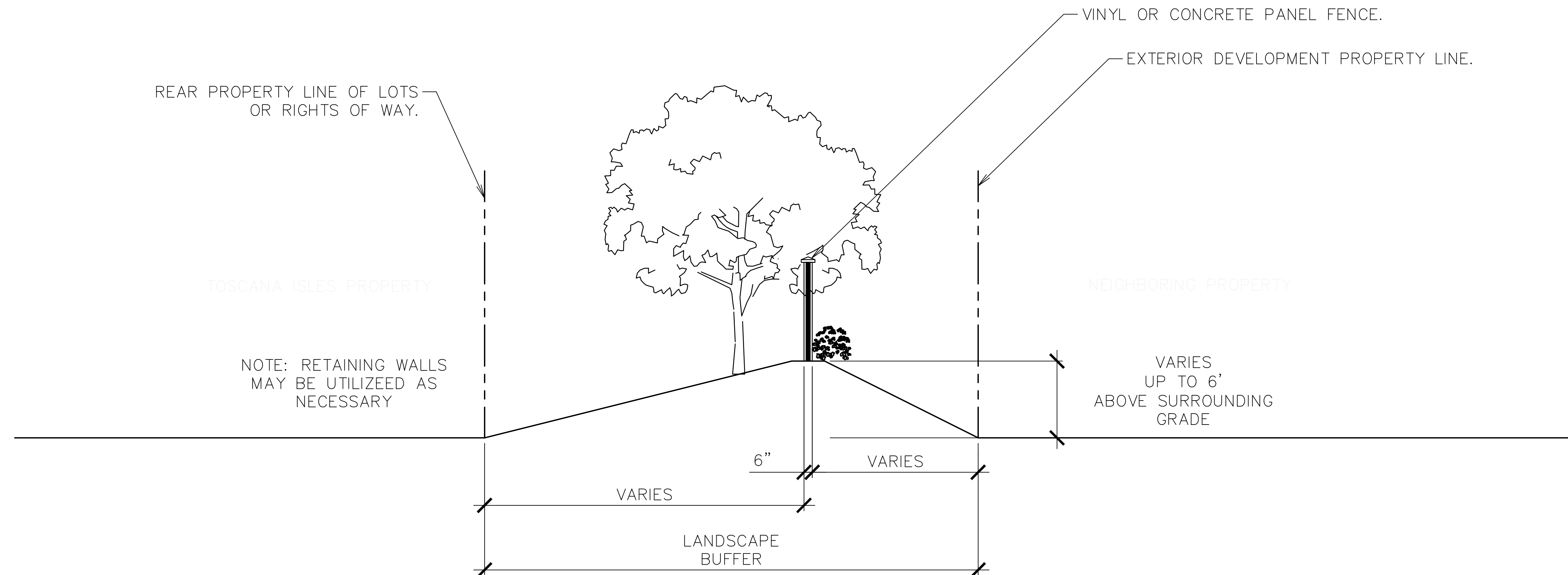

BOTANICS DESIGN GROUP, LLC
 3027 Via San Marco Court
 Fort Myers, FL 33905
 BUS. LIC # LC26000503
 WWW.BOTANICSDSIGNGROUP.COM
 PH: 239-839-7151
 EMAIL: JOSH@BOTANICSDSIGNGROUP.COM

SIGN AND SEALED BY:
 REG. LA # 01750
 JOSEPH KELLEY, P.L.A.

REVISIONS	
DATE	DESCRIPTION

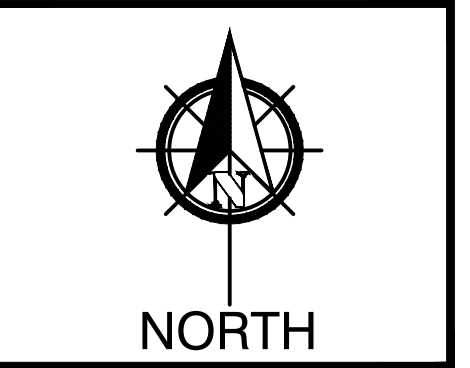

CLIENT NAME:
 TOSCANA ISLES
 COMMUNITY DEVELOPMENT
 DISTRICT

TOSCANA ISLES
 TYPICAL TYPE A BUFFER PLAN
 CROSS SECTION
 CITY OF VENICE, FLORIDA

LA-1CS
 2 of 6
 DATE: 09/07/2018
 DRAWN BY: JHK

BUFFER B: TYPICAL 100' SECTION

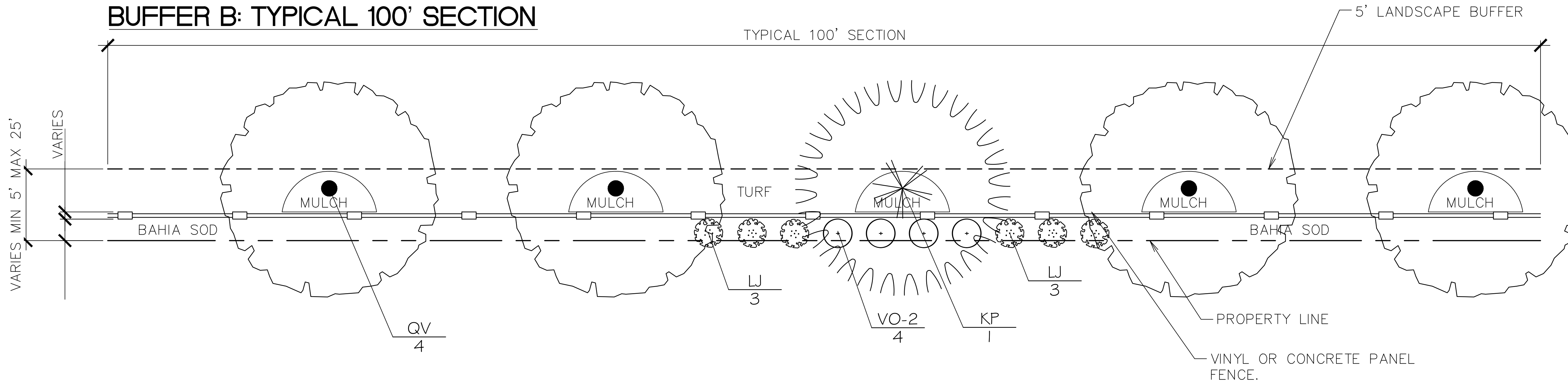

PLANT_SCHEDULE

TREES	BOTANICAL NAME	COMMON NAME	CONT	CAL	H	QTY
KP	Koelreuteria paniculata Full dense foliage, nice character	Golden Rain Tree	25 gallon min.	3" minimum		1
QV	Quercus virginiana Full dense symmetrical canopy, straight unscarred trunk	Southern Live Oak	25 gallon min.	3" minimum		4
SHRUBS	BOTANICAL NAME	COMMON NAME	CONT	H	W	QTY
LJ	Ligustrum japonicum Full, dense foliage to base, dark green	Japanese Privet	3 gal	24"	24"	6
VO-2	Viburnum odoratissimum `Awabuki` Full, dense foliage to base	Viburnum Awabuki	3 gal	24"	24"	4

PLEASE NOTE:

FOR EACH 100' SECTION OF BUFFER ALTERNATE BETWEEN SOUTHERN MAGNOLIA AND GOLDEN RAIN TREE.

PLANT_SCHEDULE_BUFFER_B_ALTERNATE

TREES	BOTANICAL NAME	COMMON NAME	CONT	CAL	H	QTY
MG	Magnolia grandiflora Full dense canopy, nice character	Southern Magnolia	25 gallon min.	3" minimum		1
QV	Quercus virginiana Full dense symmetrical canopy, straight unscarred trunk	Southern Live Oak	25 gallon min.	3" minimum		4
SHRUBS	BOTANICAL NAME	COMMON NAME	CONT	H	W	QTY
LJ	Ligustrum japonicum Full, dense foliage to base, dark green	Japanese Privet	3 gal	24"	24"	6
VO-2	Viburnum odoratissimum `Awabuki` Full, dense foliage to base	Viburnum Awabuki	3 gal	24"	24"	4

PLEASE NOTE:

BUFFER B:

- FOR EACH 10' OF FENCE, AN AVERAGE OF ONE SHRUB OR VINE SHOULD BE PLANTED ABUTTING SUCH FENCE, BUT THESE NEED NOT BE SPACED 10' APART.

- SHRUBS OR VINES SHALL BE PLANTED ALONG THE PROPERTY LINE SIDE OF SUCH FENCE, UNLESS THEY ARE OF SUFFICIENT HEIGHT AT THE TIME OF PLANTING TO BE READILY VISIBLE OVER THE TOP OF SUCH FENCE.

- THE REMAINDER OF THE REQUIRED LANDSCAPE AREAS SHALL BE LANDSCAPED WITH GRASS, GROUND COVER OR OTHER LANDSCAPE TREATMENT.

- THE FENCE SHALL BE SO LOCATED WITHIN THE LANDSCAPED BUFFER AREA AS TO PERMIT MAINTENANCE WITHOUT TRESPASS ON ADJACENT PROPERTY.

- PEDESTRIAN AND VEHICULAR INTERCONNECTIONS TO ADJOINING PUBLIC AND PRIVATE ROADWAYS AND PROPERTIES SHALL BE PERMITTED.

- ALL BUFFER AREAS SHALL BE COVERED BY GRASS, VEGETATIVE GROUND COVERINGS, OR MULCH IN AREAS NOT UTILIZED FOR TREE AND SHRUB PLANTINGS AND INCLUDE AT LEAST ONE CANOPY TREE FOR EACH 20 LINEAL FEET OF BUFFER. TREES SHALL HAVE A TRUNK DIAMETER OF AT LEAST 3" (MEASURED AT 6" ABOVE THE GROUND) AND BE A MINIMUM OF 25 GALLON CONTAINER SIZE OR HAVE A MINIMUM 2' DIAMETER ROOT BALL, IF FIELD GROWN. TREES SHALL BE FLORIDA #1 OR BETTER QUALITY AS PER GRADES AND STANDARDS FOR NURSERY PLANTS (FLORIDA DEPARTMENT OF AGRICULTURE AND CONSUMER SERVICES.)

- APPLICANT MAY SUBSTITUTE ALTERNATE SPECIES OF TREES AND SHRUBS BASED ON MATERIAL SELECTIONS AND AVAILABILITY AT TIME OF PLANTING.

- APPLICANT AT IT'S DISCRETION, MAY INSTALL ADDITIONAL/ENHANCED BUFFER LANDSCAPING BEYOND THE MINIMUM SHOWN ON THIS PLAN.

- BUFFER MAY BE PLANTED ON BERM.

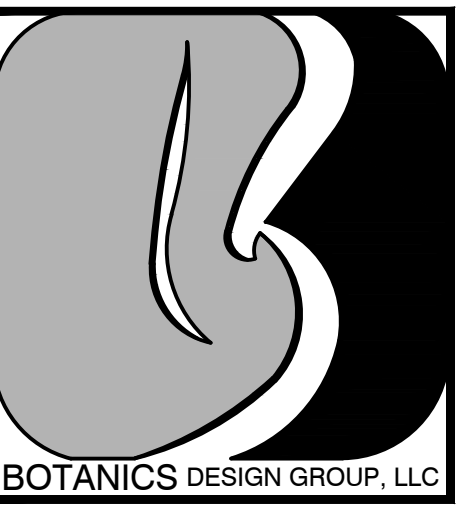

BOTANICS DESIGN GROUP, LLC
3027 Via San Marco Court
Fort Myers, FL 33905
BUS. LIC # LC26000503
WWW.BOTANICSDSIGNGROUP.COM
PH: 239-839-7151
EMAIL: JOSH@BOTANICSDSIGNGROUP.COM

SIGN AND SEALED BY:
REG. LA # 01750
JOSEPH KELLEY, P.L.A.

REVISIONS	
DATE	DESCRIPTION



CLIENT NAME:
TOSCANA ISLES
COMMUNITY DEVELOPMENT
DISTRICT

TOSCANA ISLES
TYPICAL TYPE B BUFFER PLAN
CITY OF VENICE, FLORIDA

LA-2
4 of 6
DATE: 09/07/2018
DRAWN BY: JHK

BUFFER B: TYPICAL 100' SECTION - ELEVATION

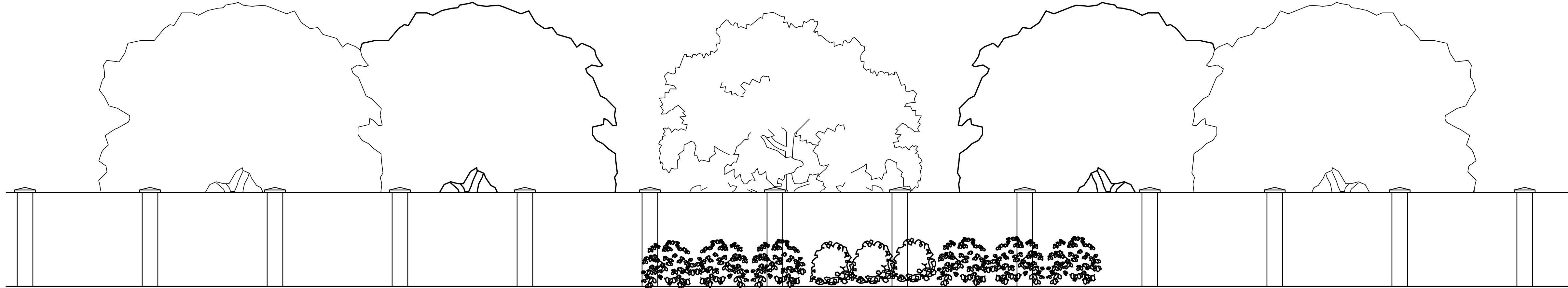

BUFFER B: SECTION

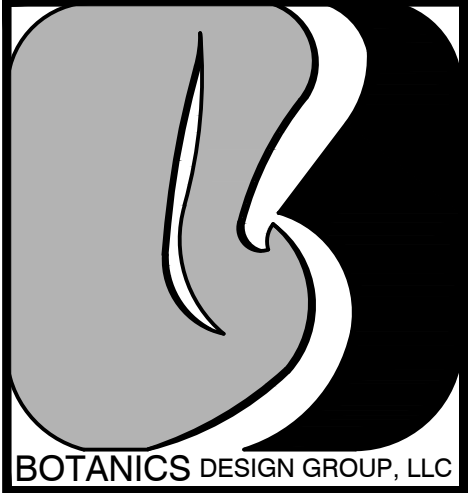
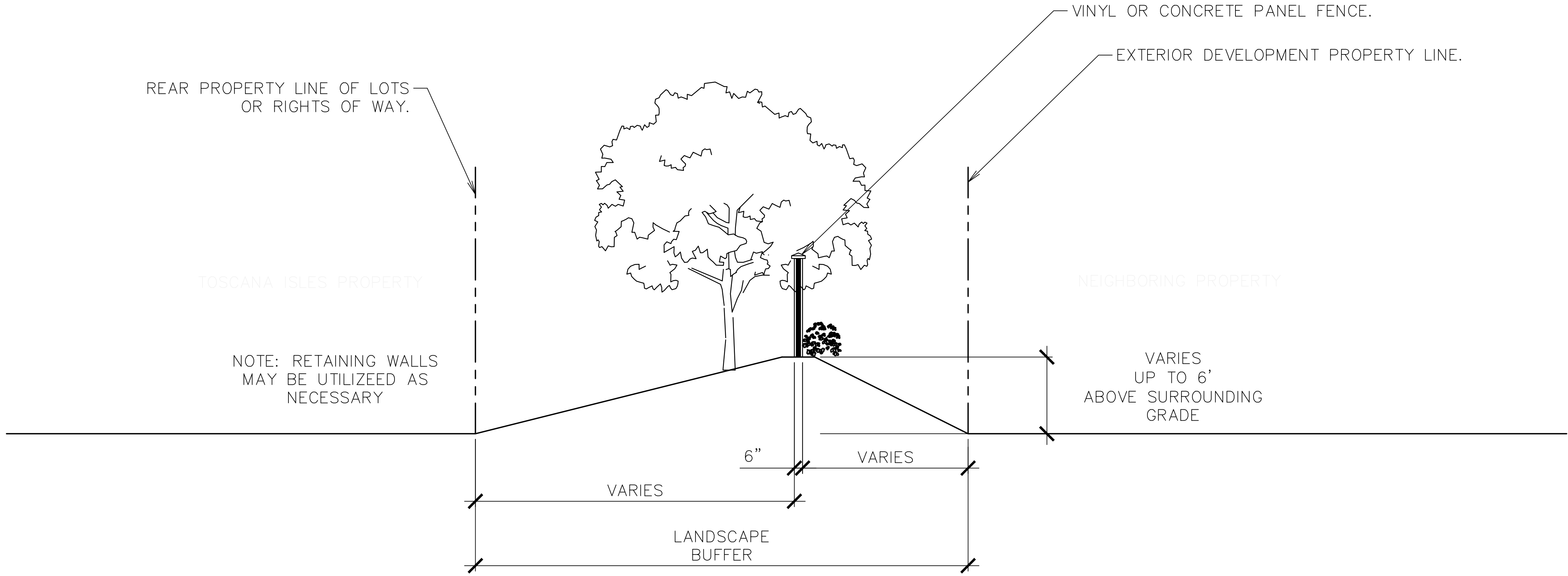

BOTANICS DESIGN GROUP, LLC
 3027 Via San Marco Court
 Fort Myers, FL 33905
 BUS. LIC # LC26000503
 WWW.BOTANICSDSIGNGROUP.COM
 PH: 239-839-7151
 EMAIL: JOSH@BOTANICSDSIGNGROUP.COM

SIGN AND SEALED BY:
 REG. LA # 01750
 JOSEPH KELLEY, P.L.A.

REVISIONS	
DATE	DESCRIPTION

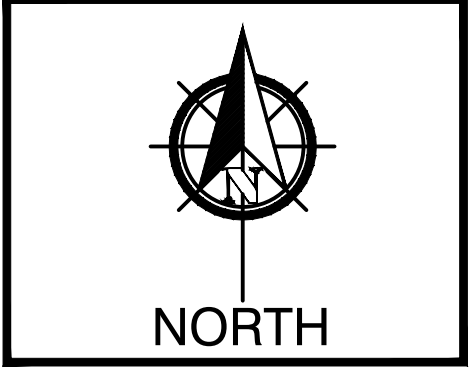

CLIENT NAME:
 TOSCANA ISLES
 COMMUNITY DEVELOPMENT
 DISTRICT

TOSCANA ISLES
 TYPICAL TYPE B BUFFER PLAN
 CROSS SECTION
 CITY OF VENICE, FLORIDA

LA-2CS
 4 of 6
 DATE: 09/07/2018
 DRAWN BY: JHK

BUFFER C: TYPICAL 100' SECTION

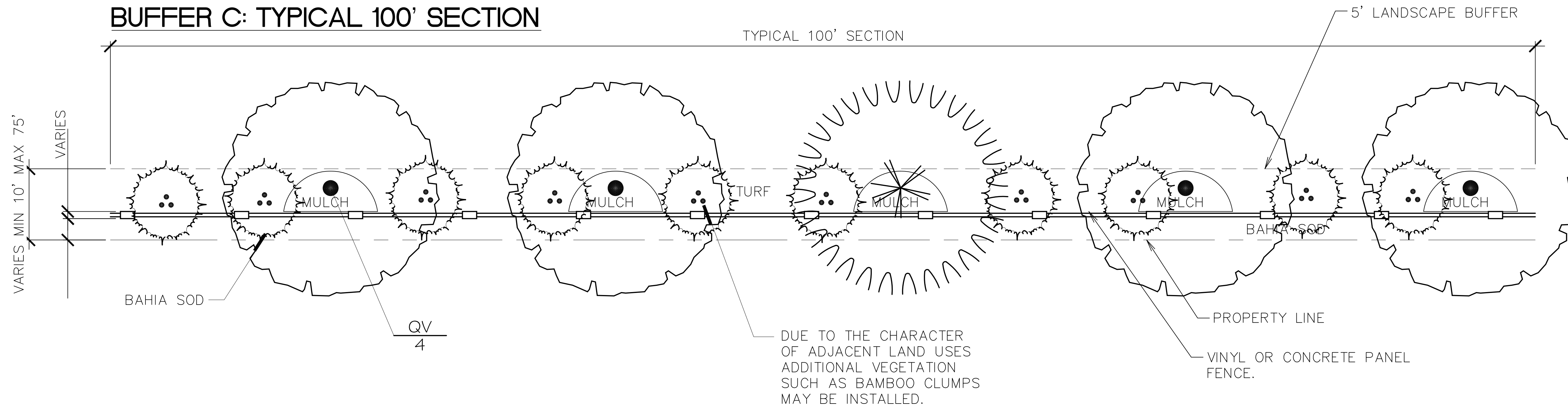

PLANT_SCHEDULE_C

TREES	BOTANICAL NAME	COMMON NAME	CONT	CAL	H	QTY
KP	Koelreutena paniculata	Golden Rain Tree	25 gallon min.	3"	minimum	1
	Full dense foliage, nice character					
QV	Quercus virginiana	Southern Live Oak	25 gallon min.	3"	minimum	4
	Full dense symmetrical canopy, straight unscarred trunk					

PLEASE NOTE:

FOR EACH 100' SECTION OF BUFFER ALTERNATE BETWEEN SOUTHERN MAGNOLIA AND GOLDEN RAIN TREE.

PLANT_SCHEDULE_BUFFER_C_ALTERNATE

TREES	BOTANICAL NAME	COMMON NAME	CONT	CAL	H	QTY
MG	Magnolia grandiflora	Southern Magnolia	25 gallon min.	3"	minimum	1
	Full dense canopy, nice character					
QV	Quercus virginiana	Southern Live Oak	25 gallon min.	3"	minimum	4
	Full dense symmetrical canopy, straight unscarred trunk					

PLEASE NOTE:

BUFFER C:

- THE PORTIONS OF BUFFER C ADJACENT TO KNIGHTS TRAIL ROAD WILL BE DESIGNED THROUGH A SUBSEQUENT SITE AND DEVELOPMENT PLAN SUBMISSION.
- THE REMAINDER OF THE REQUIRED LANDSCAPE AREAS SHALL BE LANDSCAPED WITH GRASS, GROUND COVER OR OTHER LANDSCAPE TREATMENT.
- THE FENCE SHALL BE SO LOCATED WITHIN THE LANDSCAPED BUFFER AREA AS TO PERMIT MAINTENANCE WITHOUT TRESPASS ON ADJACENT PROPERTY.
- PEDESTRIAN AND VEHICULAR INTERCONNECTIONS TO ADJOINING PUBLIC AND PRIVATE ROADWAYS AND PROPERTIES SHALL BE PERMITTED.
- ALL BUFFER AREAS SHALL BE COVERED BY GRASS, VEGETATIVE GROUND COVERINGS, OR MULCH IN AREAS NOT UTILIZED FOR TREE AND SHRUB PLANTINGS AND INCLUDE AT LEAST ONE CANOPY TREE FOR EACH 20 LINEAL FEET OF BUFFER. TREES SHALL HAVE A TRUNK DIAMETER OF AT LEAST 3" (MEASURED AT 6" ABOVE THE GROUND) AND BE A MINIMUM OF 25 GALLON CONTAINER SIZE OR HAVE A MINIMUM 2' DIAMETER ROOT BALL, IF FIELD GROWN. TREES SHALL BE FLORIDA #1 OR BETTER QUALITY AS PER GRADES AND STANDARDS FOR NURSERY PLANTS (FLORIDA DEPARTMENT OF AGRICULTURE AND CONSUMER SERVICES.)
- APPLICANT MAY SUBSTITUTE ALTERNATE SPECIES OF TREES AND SHRUBS BASED ON MATERIAL SELECTIONS AND AVAILABILITY AT TIME OF PLANTING.
- APPLICANT AT IT'S DISCRETION, MAY INSTALL ADDITIONAL/ENHANCED BUFFER LANDSCAPING BEYOND THE MINIMUM SHOWN ON THIS PLAN.
- BUFFER MAY BE PLANTED ON BERM.

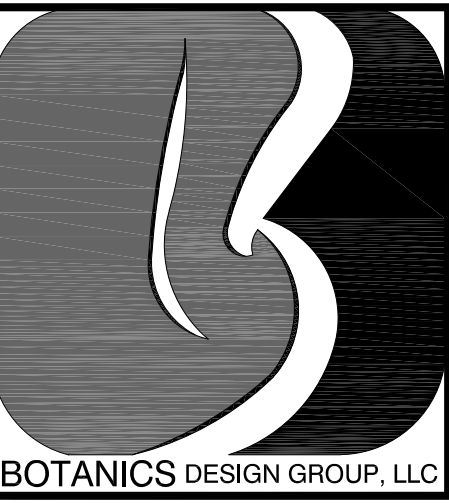

BOTANICS DESIGN GROUP, LLC
 3027 Via San Marco Court
 Fort Myers, FL 33905
 BUS. LIC # LC2600503
 WWW.BOTANICSDSIGNGROUP.COM
 PH: 239-639-7151
 EMAIL: JOSH@BOTANICSDSIGNGROUP.COM

SIGN AND SEALED BY:
 REG. LA # 01750
 JOSEPH KELLEY, RLA

REVISIONS	
DATE	DESCRIPTION

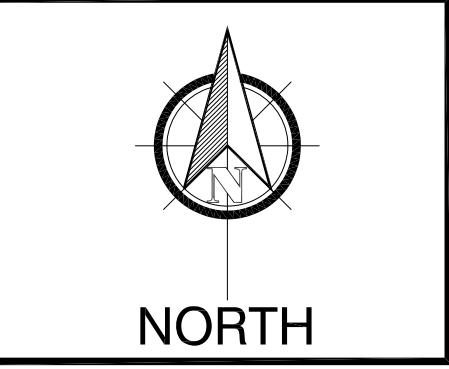

CLIENT NAME:
 TOSCANA ISLES
 COMMUNITY DEVELOPMENT
 DISTRICT

TOSCANA ISLES
TYPICAL TYPE C BUFFER PLAN
 CITY OF VENICE, FLORIDA

BUFFER C: TYPICAL 100' SECTION - ELEVATION

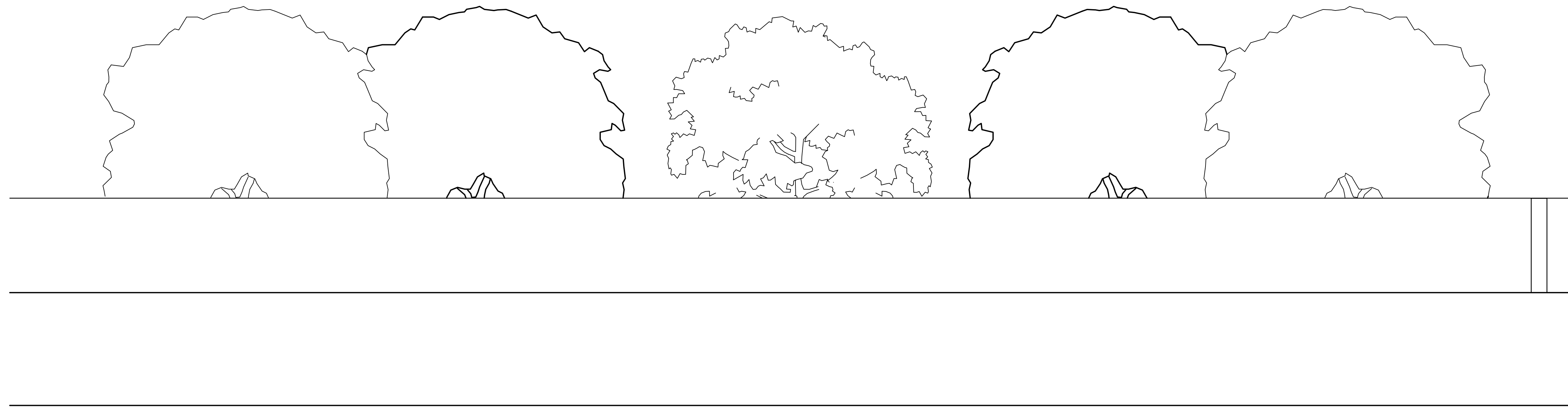

BUFFER C: SECTION

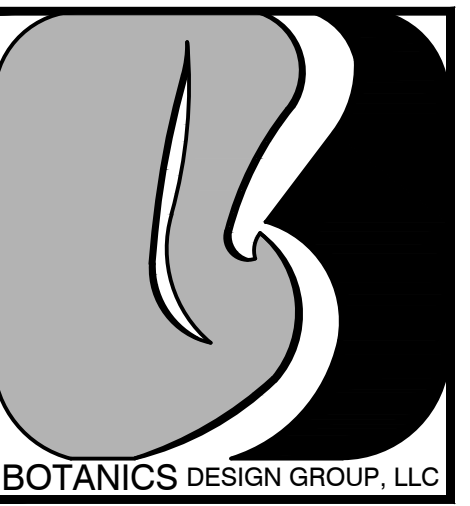
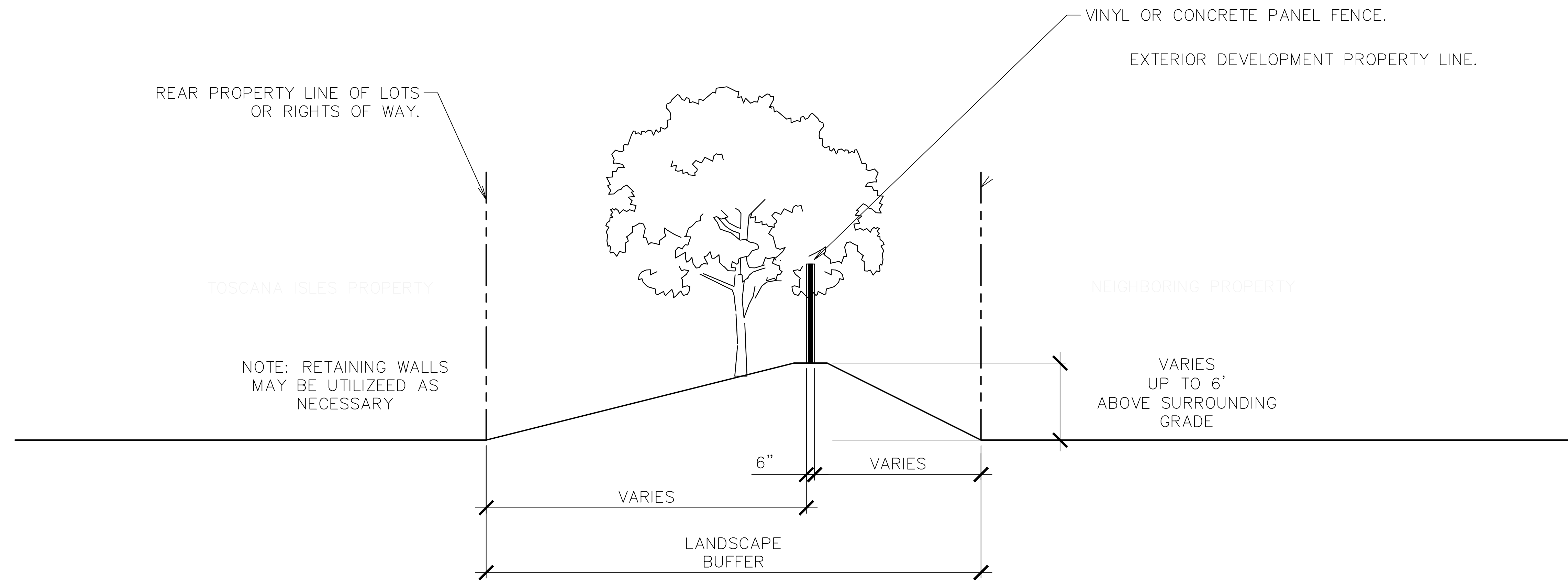

BOTANICS DESIGN GROUP, LLC
 3027 Via San Marco Court
 Fort Myers, FL 33905
 BUS. LIC # LC26000503
 WWW.BOTANICSDSIGNGROUP.COM
 PH: 239-839-7151
 EMAIL: JOSH@BOTANICSDSIGNGROUP.COM

SIGN AND SEALED BY:
 REG. LA # 01750
 JOSEPH KELLEY, P.L.A.

REVISIONS	
DATE	DESCRIPTION

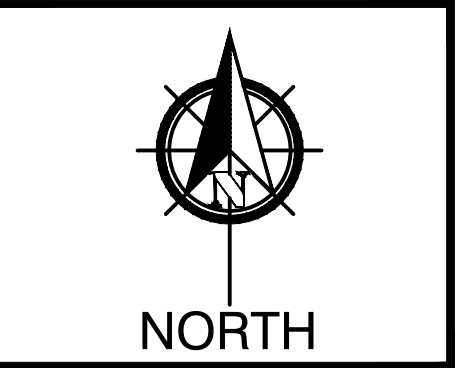

CLIENT NAME:
 TOSCANA ISLES
 COMMUNITY DEVELOPMENT
 DISTRICT

TOSCANA ISLES
 TYPICAL TYPE C BUFFER PLAN
 CROSS SECTION
 CITY OF VENICE, FLORIDA

LA-3CS
 6 of 6
 DATE: 09/07/2018
 DRAWN BY: JHK