

Prepared by: City Clerk

**ORDINANCE NO. 2024-06**

**AN ORDINANCE OF THE CITY OF VENICE, FLORIDA, GRANTING PUD AMENDMENT PETITION NO. 23-63RZ FOR THE GCCF PLANNED UNIT DEVELOPMENT (PUD) LOCATED SOUTH OF LAUREL ROAD EAST, NORTH OF BORDER ROAD, EAST OF I-75 (323.56± ACRES), BY INCREASING THE DENSITY FROM 4.3 TO 5.0 DWELLING UNITS PER ACRE; PROVIDING FOR REPEAL OF ALL ORDINANCES IN CONFLICT HERewith; PROVIDING FOR SEVERABILITY; AND PROVIDING AN EFFECTIVE DATE**

**WHEREAS**, PUD Amendment Petition No. 23-63RZ requests an amendment to the GCCF Planned Unit Development (PUD) by increasing the density from 4.3 to 5.0 dwelling units per acre; and

**WHEREAS**, the subject property has been found to be located within the corporate limits of the City of Venice; and

**WHEREAS**, the City of Venice Planning Commission has been designated as the local planning agency in accordance with F.S. 163.3174; and

**WHEREAS**, the Planning Commission held a noticed public hearing on March 5, 2024, regarding the Petition and, based upon the evidence and testimony received at the public hearing, voted to recommend approval of the Petition; and

**WHEREAS**, the Venice City Council has received and considered the report of the Planning Commission concerning the Petition; and

**WHEREAS**, City Council held a duly noticed public hearing on the Petition in accordance with the requirements of the City's Code of Ordinances, and has considered the evidence and testimony received at said public hearing.

**NOW, THEREFORE, BE IT ORDAINED BY THE CITY COUNCIL OF THE CITY OF VENICE, FLORIDA:**

**SECTION 1.** The Whereas clauses above are ratified and confirmed as true and correct.

**SECTION 2.** The City Council hereby makes the following findings of fact:

A. The Council has received and considered the report of the Planning Commission recommending approval of the Petition.

B. The Council held, after due public notice, a public hearing on the Petition and considered the evidence and testimony received at said public hearing.

C. The proposed PUD amendment of the property described herein is in accordance with and meets the requirements of the Land Development Code and is consistent with the City of Venice Comprehensive Plan.

**SECTION 3.** PUD Amendment Petition No. 23-63RZ is hereby approved, increasing allowable density in the GCCF PUD from 4.3 to 5.0 dwelling units per acre. The GCCF Planned Unit Development (PUD) Binding Master Plan (BMP) dated December 6, 2023, attached hereto as Exhibit “A”, is hereby adopted and incorporated herein by reference.

Property Description:

As depicted on the map shown below consisting of 323.56± acres and as further described in Exhibit “B”.

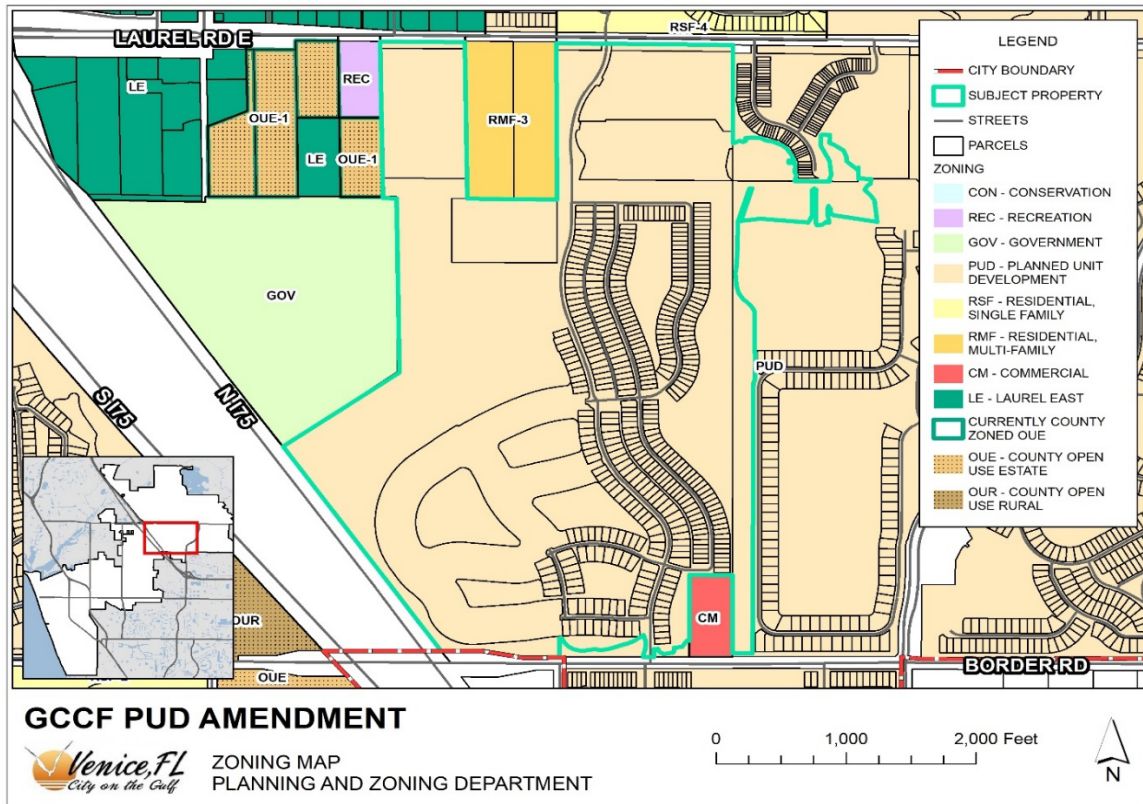

Any discrepancy between the legal description and the map shall resolve in favor of the map.

**SECTION 4.** All Ordinances or parts of Ordinances in conflict herewith shall be and the same are hereby repealed.

**SECTION 5.** If any part, section, subsection, or other portion of this ordinance or any application thereof to any person or circumstance is declared void, unconstitutional, or invalid for any reason, such part, section, subsection, or other portion, or the prescribed application thereof, shall be severable, and the remaining provisions of this ordinance, and all applications thereof not having been declared void, unconstitutional, or invalid, shall remain in full force and effect.

**SECTION 6. Effective date.** This ordinance shall take effect immediately upon its approval and adoption as provided by law.

**PASSED BY THE CITY COUNCIL OF THE CITY OF VENICE, FLORIDA, THIS 23<sup>RD</sup> DAY OF APRIL 2024.**

First Reading: April 9, 2024  
Final Reading: April 23, 2024

Adoption: April 23, 2024

\_\_\_\_\_  
Nick Pachota, Mayor

Attest:

\_\_\_\_\_  
Kelly Michaels, MMC, City Clerk

I, Kelly Michaels, MMC, City Clerk of the City of Venice, Florida, a municipal corporation in Sarasota County, Florida, do hereby certify that the foregoing is a full and complete, true and correct copy of an Ordinance duly adopted by the City of Venice Council, a meeting thereof duly convened and held on the 23<sup>rd</sup> day of April 2024 a quorum being present.

**WITNESS** my hand and the official seal of said City this 23<sup>rd</sup> day of April 2024.

\_\_\_\_\_  
Kelly Michaels, MMC, City Clerk

Approved as to form:

\_\_\_\_\_  
Kelly Fernandez, City Attorney

**Exhibit "A"**

GCCF

PLANNED UNIT DEVELOPMENT (PUD)  
BINDING MASTER PLAN

December 6, 2023

ADOPTED BY ORDINANCE NO. 2024-\_\_\_\_\_  
\_\_\_\_\_, 2024

# GCCF PUD

## PROJECT NARRATIVE

The GCCF PUD was originally a 300 +/- acre property located south of Laurel Road, north of Border Road, east of I-75 and the City's wastewater treatment plant, and west of the Milano PUD. The property is located within the Northeast Neighborhood of the City's Comprehensive Plan and is designated Mixed Use Residential on the Future Land Use Map.

Ordinance No. 2019-19 approved the GCCF PUD for the development of a residential community consisting of detached single- family homes, paired villas, multi-family homes, assisted living facilities, amenity centers, and open space. A 25 +/- acre portion of the property was approved for House of Worship as permitted use, and Medical Office as a Special Exception Use, as an alternative to residential.

Access to the site is via Laurel Road and Border Road. Consistent with Comprehensive Plan Strategy TR-NE 1.1.4 a north/south roadway connection between Laurel Road and Border Road is required through the GCCF PUD. In addition, where common ownership with the Milano PUD to the east exists, one or more optional interconnections between the properties is permitted. The circulation plan for the GCCF PUD provides opportunities for multi-modal connectivity, and includes a linked sidewalk system for pedestrian connectivity from each of the development pods throughout the PUD. Further, sidewalk linkages along Laurel Road and Border Road are provided to the project limit.

All internal roadways will be privately owned and maintained. The on-site storm water management system will be privately owned and maintained. Water and wastewater facilities will be dedicated to the City of Venice or Sarasota County as applicable.

The PUD was previously amended by Ordinance No. 2022-20 to add 24.1 acres of open space along the eastern boundary of the PUD relocated from the adjacent Milano PUD and to modify the lot standard detail to clarify yards standards for lots with alleys. In addition, minor revisions to the approved PUD plan were approved which incorporated previously approved preliminary plat approvals regarding location of open space, stormwater ponds, internal roadways and the amenity area, the addition of a sidewalk segment on the east side of the spine road, the elimination of a "potential access point" along Border Road, and the elimination of the multi-family use for lots south of the east-west FPL easement. No other changes were proposed to the approved uses or development standards.

This amendment to the PUD increased the currently approved density from 1,300 dwelling units (4.3 units per acre) to 1,617 dwelling units (5.0 units per acre). There were no other changes to the currently approved GCCF Binding Master Plan.

## COMPLIANCE

The proposed GCCF PUD plan is consistent with all applicable elements of the City's Comprehensive Plan. Specifically, the proposed GCCF PUD is consistent with the Northeast Neighborhood plan and the existing and future land uses therein, including Strategy LU-NE 1.1.1. which designates the property Mixed Use Residential (MUR) and allows for up to five (5) dwelling units per acre.

Pursuant to Comprehensive Plan Strategy LU- NE 1.1.1. C LU-1.2.16.6.c a minimum of 50% open space will be provided including a minimum of 10% Functional and 10% Conservation Open Space.

As noted above, consistent with Strategy TR-NE 1.1.4 a north/south roadway connection between Laurel Road and Border Road will be provided through the GCCF PUD.

In addition, the GCCF PUD plan is in compliance with the applicable Intents and Strategies of the Transportation, Open Space, Housing, Infrastructure, and Public Schools Elements of the Comprehensive Plan.

Finally, the proposed GCCF PUD is in compliance with the City of Venice Land Development Code Sec. 86-130 requirements for Planned Unit Development (PUD) Districts as outlined in the below Land Use and Development Standards.

## LAND USE AND DEVELOPMENT STANDARDS

The following identifies the proposed development standards for the GCCF Planned Unit Development. In furtherance of the interpretation authority granted by the City of Venice Comprehensive Plan and Land Development Code, the Zoning Administrator shall have authority to administratively approve minor modifications of standards contained with the GCCF Planned Unit Development, excluding standards related to density, building height, buffer widths, and the addition of uses. Reasonable mitigation measures may be imposed by the Zoning Administrator to limit impacts from the requested adjustment of standards. Where the PUD master plan identifies areas for residential uses, the developer shall have the option to convert such residential use areas to open space uses.

Any standard not stated or otherwise addressed in the binding master plan is subject to Chapter 86- Land Development Code.

A. Land Uses

1) Permitted Principal Uses and Structures

- Residential single-family dwellings (detached)
- Residential single-family dwellings (attached)
- Multi-family dwellings
- Private club, community centers and civic and social organization facilities
- House of Worship
- Recreational areas
- Open Space
- Cell Tower

2) Permitted Accessory Uses and Structures

- Are customarily accessory and clearly incidental and subordinate to permitted or permissible uses and structures.
- Are located on the same lot as the permitted or permissible use or structure or on a contiguous lot in the same ownership.
- Do not involve operations or structures not in keeping with the character of the district.
- Do not involve the conduct of business on residential premises, provided that accessory home occupations shall be allowed as accessory to residential uses.

3) Special Exception Uses

- Assisted Living Facilities
- Medical Office

B. Density/ Intensity

- 1) Residential- Up to 1,617 residential units
- 2) Open Space- Minimum 50%
- 3) Non-Residential - Maximum FAR 0.5 (individual site)

C. Maximum Height of Structures

- 1) Single-Family - 3 stories up to 35' including parking.
- 2) Assisted Living, House of Worship, Medical Office- 5 stories up to 55' including parking. (For heights above 3 stories and 35', Conditional Use approval required)



## D. LOT DETAIL

### 1) Single-Family Detached

- Minimum Lot Size: 4,500 square feet
- Maximum Lot Coverage: None, except as required to meet other requirements set out in this section
- Minimum Lot Width: 40 feet
- Front Yard: 20 feet
- Side Yard: 5 feet
- Rear Yard: 10 feet
- Accessory structures/appurtenant structures including, but not limited to pool cages, may be located within five feet of the rear lot line

### 2) Single-Family Attached (Paired Villas)

- Minimum Lot Size: 4,025 square feet
- Maximum Lot Coverage: None, except as required to meet other requirements set out in this section
- Minimum Lot Width: 35 feet
- Front Yard: 20 feet
- Side Yard: 5 feet
- Rear Yard: 10 feet
- Accessory structures/appurtenant structures including, but not limited to pool cages, may be located within five feet of the rear lot line

### 3) Multi-Family

- Minimum Lot Size: 7,200 square feet
- Maximum Lot Coverage: None, except as required to meet other requirements as set out in this section
- Minimum Lot Width: 90 feet
- Front Yard: 20 feet
- Side Yard: 5 feet
- Rear Yard: 10 feet
- Accessory structures/appurtenant structures including, but not limited to pool cages, may be located within five feet of the rear lot li

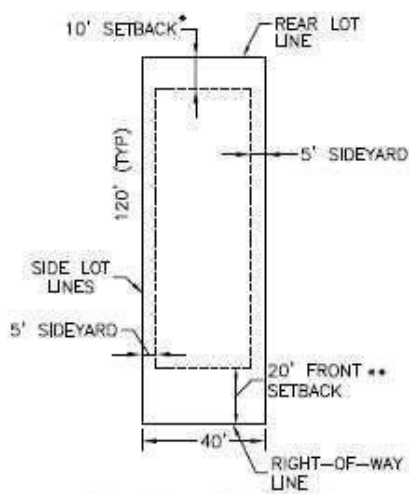

**TYPICAL LOT DETAIL**  
SINGLE FAMILY DETACHED

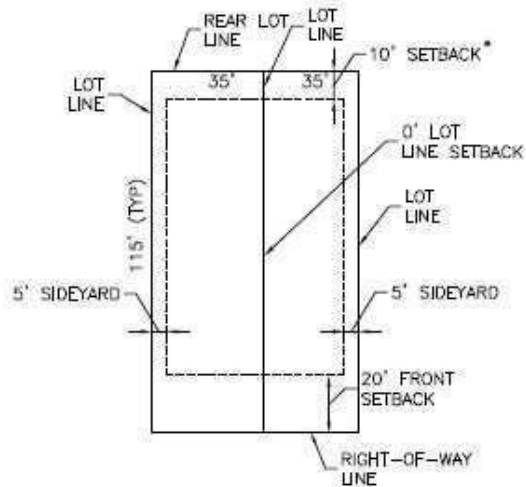

**TYPICAL LOT DETAIL**  
PAIRED VILLAS

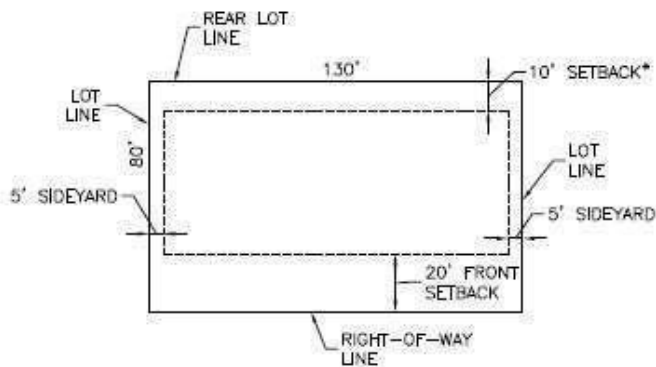

**MULTI-FAMILY LOT DETAIL**  
4 PLEX / 6 PLEX

\*\*\* REAR YARD STANDARDS SHALL APPLY FOR YARDS ADJACENT TO ALLEYS

\*\*\* Garages attached to a primary residential structure by a breezeway shall be considered accessory structures.

• ACCESSORY STRUCTURES/APPURTENANT STRUCTURES SUCH AS POOL CAGES, MAY BE LOCATED WITHIN FIVE FEET OF THE REAR LOT LINE.

\*\* FRONT SETBACK MAY BE REDUCED TO 15' WHEN THE BUILDING HAS A SIDE ENTRY GARAGE OR AN ALLEY LOADED GARAGE

**LOT DETAILS**

PROJECT: GCCF PROPERTY

CLIENT: BORDER ROAD INVESTMENT, LLC



**Stantec**

6900 Professional Parkway East, Sarasota, FL 34240-6414  
Phone 941-407-6900 • Fax 941-407-6910  
Certificate of Authorization #27013 • www.stantec.com

The Contractor shall verify and be responsible for all dimensions. DO NOT make the drawing. Any errors or omissions shall be reported to Stantec without delay. The Copyright to all designs and drawings are the property of Stantec. Reproduction or use for any purpose other than that authorized by Stantec is prohibited.

MELANIE DELEHANTY SMITH, P.E.  
FLORIDA LICENSE NO. 75447

SCALE	1" = 50'	DATE	09/2018
SHEET NO.	35/36	TWP.	38S
		R&E	19E
PROJECT NO.	215614685	INDEX NO.	215614685-001-EX203
DRAWN BY/DATE NO.	RSB/115155	SHEET NO.	1 of 2

4) Assisted Living, House of Worship, Medical Office

- Minimum Lot Size: None, except as needed to meet all other requirements set out in this section.
- Maximum Lot Coverage: None, except as required to meet other requirements set out in this section
- Lot Width: 100 feet
- Front Yard: 20 feet
- Side Yard: Six feet minimum, but in no case less than 15 feet combined side yards.
- Rear Yard: 10 feet
- Accessory structure/ appurtenant structures: 5 feet
- Buildings above 35 feet shall provide additional side and rear yards at a ratio of one foot of yard for each three feet of building height above 35 feet and a front yard of 25 feet or one-half of the building height, whichever is greater.

E. BUFFERS/ LANDSCAPING

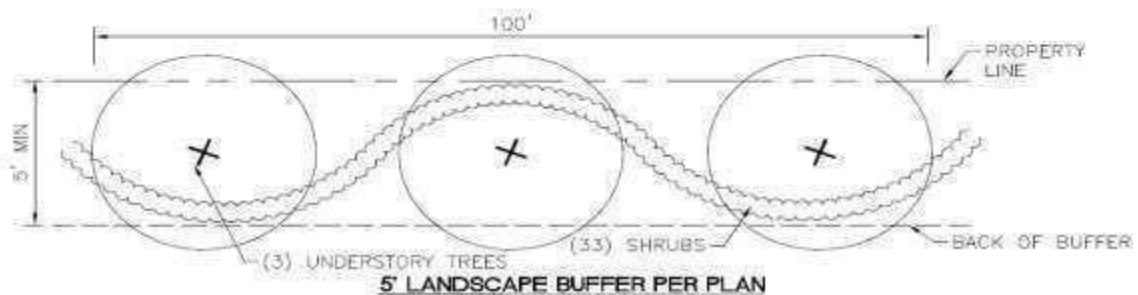
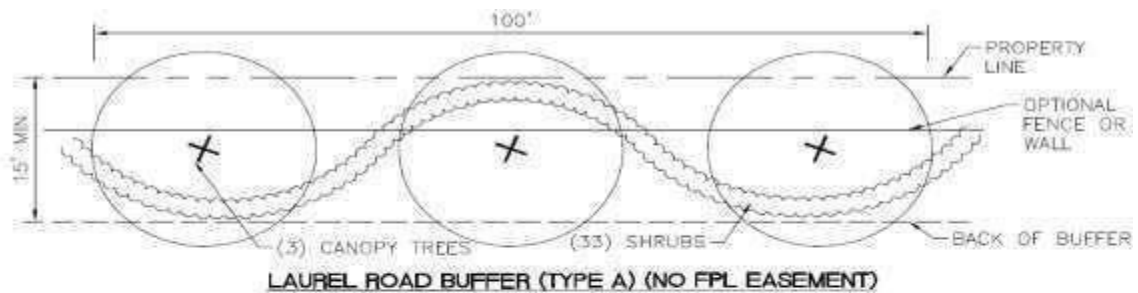

NOTES:

1. EXISTING VEGETATION TO REMAIN WHERE FEASIBLE TO SATISFY BUFFER PLANTING REQUIREMENTS.
2. TYPICAL BUFFER REQUIREMENTS WILL NOT APPLY WHERE EXISTING WETLANDS ARE TO REMAIN.
3. WHERE OVERHEAD UTILITY POLE LOCATIONS RESTRICT VERTICAL VEGETATION HEIGHTS, ACCENT TREES AS DEFINED BY SARASOTA COUNTY SHALL BE USED IN LIEU OF A CANOPY TREE.
4. BERM HEIGHTS SHALL BE LIMITED TO A RANGE 0' TO 6'.

## F. Roadway Design (Minimum Design Standards)

1) The GCCF PUD proposes the following minimum roadway design for the connection road from Laurel Road to Border Road required pursuant to Comprehensive Plan Strategy TR-NE 1.1.4. (see typical connection roadway standard below)

- Right-of-Way: 52 feet
- Travel Lanes: 10 feet
- Sidewalk: 5 feet (x2)
- Bike Lane 4 feet (x 2)
- 2 foot curb
- One (1) tree per lot which may be placed within or adjacent to the ROW, minimum 3" caliper at installation

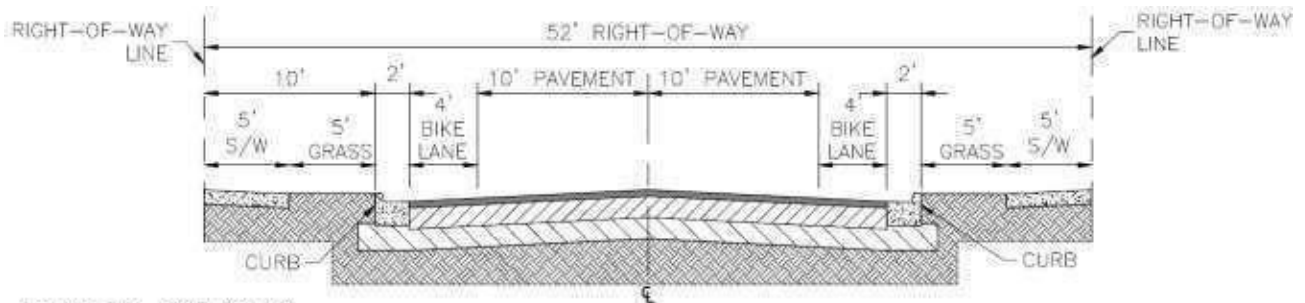

### CONNECTOR ROAD NOTES:

1. THE TWO 5' SIDEWALKS CAN BE SUBSTITUTED FOR ONE 8' MURT. THE 8' MURT MAY BE PLACED ON EITHER SIDE OF THE ROAD AND THE REMAINDER OF THE COMPONENTS OF THE SECTION CAN BE SHIFTED TO MAINTAIN THE 52' MINIMUM CROSS SECTION.
2. ON STREET PARKING MAY BE ADDED TO THE SECTION SUCH THAT THE 52' MINIMUM R-O-W IS INCREASED TO ACCOMMODATE THE SPACE NEEDED FOR THE ADDITIONAL PARKING.

### TYPICAL CONNECTION ROADWAY SECTION (SECTION A-A)

2) The GCCF PUD proposes an alternative minimum neighborhood roadway design with the following standards (see typical neighborhood roadway section below):

- Right-of-Way: 43 feet
- Travel Lanes: 10 feet
- Sidewalk: 5 feet, one side of street only
- 2 foot curb
- One (1) tree per lot which may be placed within or adjacent to the ROW, minimum 3" caliper at installation

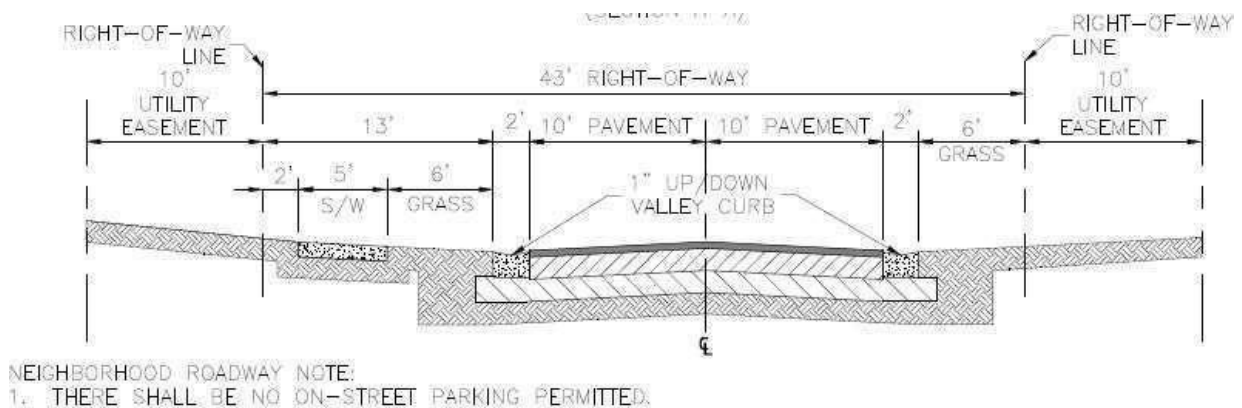

**TYPICAL NEIGHBORHOOD ROADWAY SECTION**  
 (SECTION B-B)

3) The GCCF PUD proposes an alley design with the following minimum standards (see typical alley section below):

- Right-of-Way: 20 feet

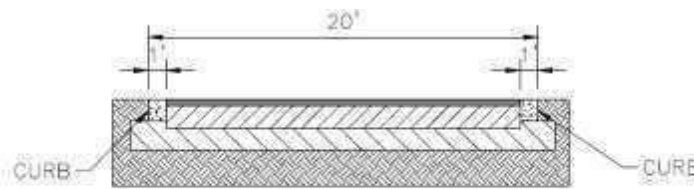

**TYPICAL ALLEY SECTION**  
 (SECTION C-C)

4) Pursuant to Sec. 86-233(3) City Council Approval of dead-end streets (cul-de-sacs) up to 1,200 feet in length is requested.

G. SIGNAGE: No signs are permitted in the GCCF PUD except:

- 1) One non-illuminated temporary construction project ground sign per street frontage, not exceeding 32 square feet in area, such sign not to be erected more than 60 days prior to the time actual construction begins, and to be removed upon completion of actual construction. If construction is not begun within 60 days or if construction is not continuously and actively prosecuted to completion, the sign shall be removed.
- 2) One community identification, monument-style ground sign, or wall sign not to exceed nine (9) feet in height and twenty (20) feet in width, on each side, or in the median and one side, of each vehicular access point off Border Road and Laurel Road.
- 3) One wall or monument-style ground sign, or wall sign not over eight square feet in area, to identify a private club.
- 4) Assisted Living Facility, Medical Office, House of Worship Signage- One monument-style ground sign, or wall sign for each lot or parcel, not over 75 square feet in area.

## PROPOSED GCCF PUD MODIFICATION TO STANDARDS

- 1) A modification to the requirements of Sec. 86-130 (q), concerning the requirement that no structure, including pool cages, shall be located closer to any perimeter property line than two times the height of such structure, is requested. The proposed modification is to reduce the required setback from perimeter property lines to one times the building height.

The proposed modification request is justified based upon the low intensity of the development plan, the extensive perimeter buffers and the significant amount of open space otherwise provided.

- 2) A modification to the requirements of Sec 86-232(5) concerning the roadway design standards is proposed and an alternative neighborhood roadway design is proposed. The proposed modification reduces right-of way width from 52' to 43', allows for sidewalks on one side of the neighborhood roadway only, and eliminates bike lanes for the neighborhood roadways.

The proposed modification request is justified based upon the protection of wetlands and their buffers afforded by the modification, and the low intensity of the development plan.

- 3) A modification to the requirements of Sec 87- 3.18.B.2.a to reduce the minimum required separation of a residential driveway from the intersection of the edge of pavement of two streets from 40 feet to 30 feet.

The proposed modification is justified based upon the currently approved 40 foot lot widths in the PUD which make provision of a 40 foot driveway separation for reasonably sized driveways impossible for the limited number of lots located at the intersection of two streets.



PLANNED UNIT DEVELOPMENT PLANS FOR

# GCCF PROPERTY

PART OF SECTIONS 35 & 36, TOWNSHIP 38 SOUTH, RANGE 19 EAST  
CITY OF VENICE  
SARASOTA COUNTY, FL

A DEVELOPMENT BY BORDER ROAD INVESTMENTS, LLC  
5800 LAKEWOOD RANCH BOULEVARD  
SARASOTA, FL 34240  
(941) 328-1111



**INDEX TO SHEETS**

SHEET NO.	DESCRIPTION
1	COVER SHEET
2	MASTER SITE AND CIRCULATION PLAN

Civil Engineering | Land Surveying | 8340 Consumer Court Sarasota, FL 34240 | Phone: (941) 377-9178 | www.amengfl.com | CA #33105 | LB #4334

REV. No.	REV. DATE	REVISION DESCRIPTION	BY
2	05/17/22	RESPONSE TO CITY COMMENTS	BRC
1	03/30/22	RESPONSE TO CITY COMMENTS	BRC

CALL BEFORE YOU DIG!  
"SUNSHINE STATE ONE-CALL CENTER"  
1-800-432-4770  
THE CONTRACTOR SHALL NOTIFY "SUNSHINE STATE ONE-CALL CENTER" AND ALL OTHER UTILITIES FOR LOCATION OF EXISTING FACILITIES PRIOR TO BEGINNING CONSTRUCTION.

ISSUE DATE: **JANUARY 27, 2022** BRC

ISSUE DESCRIPTION: **PUD MODIFICATION**

Civil Engineering | Land Surveying



**AM ENGINEERING, LLC.**

8340 Consumer Court Sarasota, FL 34240  
Phone: (941) 377-9178 | www.amengfl.com  
CA #33105 | LB #4334

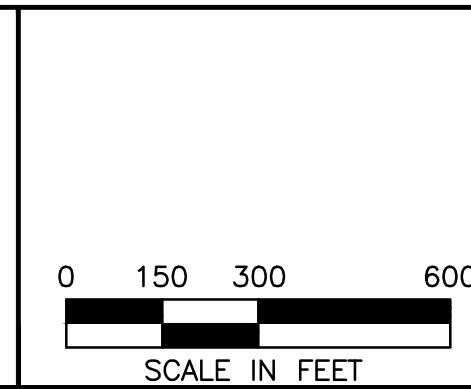

CLIENT:	BORDER ROAD INVESTMENTS, LLC
PROJECT:	GCCF PROPERTY
TITLE:	COVER SHEET

HORIZONTAL SCALE:	1" = 300'
VERTICAL SCALE:	N/A
VERTICAL DATUM:	N/A
PROJECT NUMBER:	NEAL0016PUD
SHEET NUMBER:	1

PROJECT ENGINEER:

BOBBI R. CLAYBROOKE, PE  
DATE: \_\_\_\_\_  
FLORIDA P.E. No. 90804

Page 16 of 24, Ord. No. 2024-06





### LAND USE AREA TABLE

LAND USE	AREA AS SHOWN (AC)	% AS SHOWN	REQUIRED AREA (AC)	REQUIRED %
SINGLE FAMILY RESIDENTIAL	89.01	27.5		
AMENITY AREA	2.10	0.6		
MULTI-FAMILY/SINGLE FAMILY	28.64	8.9		
MEDICAL OFFICE/MULTIFAMILY/HOUSE OF WORSHIP/ASSISTED LIVING FACILITY	17.46	5.4		
R.O.W.	23.95	7.4		
OPEN SPACE	45.94	14.2		
MITIGATION AREA	8.44	2.6		
EXISTING WETLAND	22.49	7.0		
EXISTING LAKES/PROPOSED LAKES	50.96	15.8		
OTHER OPEN SPACES	10.47	3.2		
OPEN SPACE FROM MILANO PUD	24.10	7.4		
<b>OPEN SPACE TOTAL</b>	<b>162.40</b>	<b>50.2</b>	<b>161.78</b>	<b>50.0</b>
<b>TOTAL AREA</b>	<b>323.56</b>	<b>100.0</b>		

- PROPOSED 5' SIDEWALKS
- PROPOSED 8' MULTI-USE RECREATIONAL TRAIL (MURT)
- PROPOSED 8' OPTIONAL MULTI-USE RECREATIONAL TRAIL (MURT), FINAL PATH TO BE DETERMINED

- NOTES:**
- WELL SITES TO BE RELOCATED SUBJECT TO MUTUAL AGREEMENT BETWEEN OWNER AND CITY.
  - ENTRY GATES TO BE OPENED DURING EMERGENCY AS DETERMINED BY VENICE POLICE AND FIRE DEPARTMENTS.
  - THE SIDEWALKS SHOWN ARE CONCEPTUAL AND MAY BE LOCATED ON THE OTHER SIDE OF THE ROAD.

REV. No.	REV. DATE	REVISION DESCRIPTION	BY
2	05/17/22	RESPONSE TO CITY COMMENTS	BRC
1	03/30/22	RESPONSE TO CITY COMMENTS	BRC

CALL BEFORE YOU DIG!  
 "SUNSHINE STATE ONE-CALL CENTER"  
 1-800-432-4770  
 THE CONTRACTOR SHALL NOTIFY "SUNSHINE STATE ONE-CALL CENTER" AND ALL OTHER UTILITIES FOR LOCATION OF EXISTING FACILITIES PRIOR TO BEGINNING CONSTRUCTION.

ISSUE DATE: **JANUARY 27, 2022** ISSUED BY: **BRC**

**PUD MODIFICATION**

Civil Engineering | Land Surveying

**AM ENGINEERING, LLC.**

8340 Consumer Court Sarasota, FL 34240  
 Phone: (941) 377-9178 | www.amengfl.com  
 CA #33105 | LB #4334

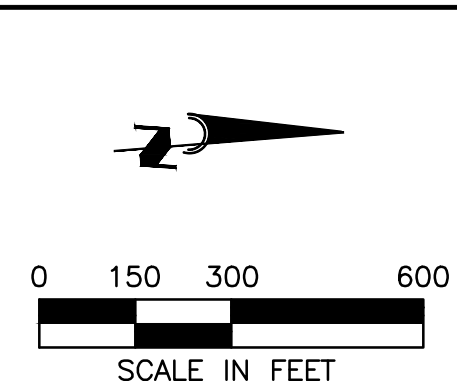

**BORDER ROAD INVESTMENTS, LLC**

**GCCF PROPERTY**

**MASTER SITE & CIRCULATION PLAN**

HORIZONTAL SCALE	1" = 300'
VERTICAL SCALE	N/A
VERTICAL DATUM	N/A
PROJECT NUMBER	NEAL0016PUD
SHEET NUMBER	<b>2</b>

PROJECT ENGINEER:  
**BOBBI R. CLAYBROOKE, PE**  
 DATE: **90804**  
 FLORIDA P.E. No. **90804**  
 Page 17 of 24, Ord. No. 2024-06



**Exhibit "B"**

**LEGAL DESCRIPTION**

**PARCEL 1:**

A parcel of land lying and being in the NW 1/4 and the SW 1/4 of Section 34, Township 38 South, Range 19 East, Sarasota County, Florida, and being more particularly described as follows:

Commence at the NW corner of said Section 34; thence along the West line of the NW 1/4 of said Section 34, S 0°50'33" E, a distance of 1342.18 feet to the SW corner of the NW 1/4 of the NW 1/4 of said Section 34; thence along the South line of said NW 1/4 of the NW 1/4 of said Section 34, S 89°29'17" E, a distance of 1470.24 feet for a Point of Beginning, said point being the NE corner of those lands as described in Official Records Book 2359, Pages 2069 and 2070, Public Records of Sarasota County, Florida; thence continue along said line, S 89°29'17" E, a distance of 425.54 feet, to the NW corner of those lands as described in Official Records Book 3024, Page 558, Public Records of Sarasota County, Florida; thence S 0°15'55" E, along the Westerly boundary line of said lands, a distance of 539.73 feet to the SW corner of said lands; thence S 89°29'01"E, along the Southerly boundary line of said lands, a distance of 292.83 feet; thence S 0°15'55" E, a distance of 524.13 feet; thence S 89°29'01" E, a distance of 517.24 feet to the East line of said NW 1/4 of Section 34, Township 38 South, Range 19 East, Sarasota County, Florida; thence S 0°15'55" E, along said East line, a distance of 2833.07 feet to the Northerly right-of-way line of Border Road; thence N 89°40'23" W, along said right-of-way line, a distance of 84.80 feet; thence N 0°19'37" E, along said right-of-way line, a distance of 17.00 feet; thence N 89°40'23" W, along said right-of-way line, a distance of 200.00 feet; thence N 80°23'38" W, along said right-of-way line, a distance of 303.93 feet; thence N 89°28'33" W, along said right-of-way line, a distance of 326.51 feet to the Northeasterly right-of-way line of State Road 93 (I-75), Florida Department of Transportation right-of-way map, Section 17075-2406; thence N 35°01'47" W, along said right-of-way line, a distance of 2115.71 feet to the most Southerly corner of those lands as described in Official Records Book 2359, Pages 2069 and 2070, Public Records of Sarasota County, Florida; thence N 54°58'13" E, along the Southeasterly boundary line of said lands, a distance of 1091.03 feet to the SE corner of said lands; thence N 0°50'28" W, along the Easterly boundary line of said lands, a distance of 138.24 feet; thence N 0°50'33" W, along the Easterly boundary line of said lands, a distance of 1338.73 feet to the Point of Beginning.

Less those lands described in Warranty Deed wherein Sarasota County, Florida, is Grantee and recorded in Official Records Instrument No. 2004206575, of the Public Records of Sarasota County, Florida.

**PARCEL 2:**

Commence at the SE corner of the SW 1/4 of Section 34, Township 38 South, Range 19 East, Sarasota County, Florida; thence N 0°17'55" W, 3390.20 feet for a Point of Beginning, thence continue N 0°17'55" W, 537.81 feet; thence N 89°31'01" W, 810.03 feet; thence S 0°17'55" E, 537.81 feet; thence S 89°31'01" E, 810.03 feet to the Point of Beginning, all lying and being in Section 34, Township 38 South, Range 19 East, Sarasota County, Florida.

Together with a 30 foot easement for ingress and egress lying on the West of the East line of the SW 1/4 of Section 34, Township 38 South, Range 19 East, Sarasota County, Florida, and lying between the South line of above described parcel and the North line of Border Road.

PARCEL 3:

Commence at the NW corner of Section 34, Township 38 South, Range 19 East, thence S 89°34'05" E 1690.65 feet along the North line of said Section 34, for the Point of Beginning; thence continue S 89°34'05" E 325.69 feet along said North line; thence S 1°03'08" E 1337.54 feet along a line parallel with the West line of said Section 34 to the South line of the NE 1/4 of the NW 1/4 of said Section 34; thence N 89°42'00" W 325.67 feet along said South line; thence N 1°03'08" W 1338.29 feet along a line parallel with the West line of said Section 34, to the Point of Beginning.

PARCEL 4:

Commence at the NW corner of Section 34, Township 38 South, Range 19 East, thence S 89°34'05" E, a distance of 1365.14 feet along the North line of said Section 34, for the Point of Beginning; thence continue S 89°34'05" E, a distance of 325.51 feet along said North line; thence S 1°03'08" E, a distance of 1338.29 feet along a line parallel with the West line of said Section 34 to the South line of the NE 1/4 of the NW 1/4 of said Section 34; thence N 89°42'00" W, a distance of 325.49 feet along said South line; thence N 1°03'08" W, a distance of 1339.04 feet along a line parallel with the West line of said Section 34, to the Point of Beginning.

PARCEL 5:

Commence at the NW corner of Section 34, Township 38 South, Range 19 East, thence S 0°50'33" E, 1342.18 feet; thence S 89°29'17" E, 1470.24 feet; thence S 89°29'17" E, 425.54 feet; thence S 0°15'55" East, 539.73; thence S 89°29'01" E, 292.83 feet for a Point of Beginning; thence S 0°15'55" E, 524.13 feet; thence S 89°29'01" E, 517.24 feet; thence N 0°17'55" W, 524.13 feet; thence N 89°31'01" W, 517.20 feet to the Point of Beginning.

PARCEL 6:

A portion of Section 34, Township 38 South, Range 19 East, Sarasota County, Florida, being more particularly described as follows:

Commence at the SW corner of SE 1/4 of Section 34, Township 38 South, Range 19 East, Sarasota County, Florida; thence S 89°52'24" E along the South line of said Section 34, a distance of 667.01 feet for the Point of Beginning; thence continue S 89°52'24" E along said South line a distance of 332.66 feet; thence N 00°10'44" W a distance of 100.00 feet to the SW corner of Wade property as recorded in Official Records Book 1037, Page 1561, of the Public Records of Sarasota County, Florida; thence N 89°52'24" W along a line a distance of 100.00 feet from and parallel with said South line a distance of 332.66 feet to the SW corner of Prestia property as described in Official Records Book 1035, Page 1096, of the Public Records of Sarasota County, Florida; thence S 00°10'44" E a distance of 100.00 feet to the Point of Beginning, LESS: The South 33.00 feet of the West 20.00 feet of the East 665.23 feet of the South 100.00 feet of the West 1/2 of the East 1/2 of Section 34, Township 38 South, Range 19 East, Sarasota County, Florida

Together with:

Commence at a point 100.00 feet North and 667.11 feet East of the SW corner of the SE 1/4 of Section 34, Township 38 South, Range 19 East, Sarasota County, Florida, for a Point of Beginning; thence continue East a distance of 332.66 feet; thence N 0°16'58" W a distance of 654.73 feet; thence West a distance of 332.66 feet; thence S 0°16'58" E a distance of 654.73 feet to the Point of Beginning. All lying and being in the West 1/2 of the East 1/2 of Section 34, Township 38 South, Range 19 East, Sarasota County, Florida.

PARCEL 7:

Commence at a concrete monument 100 feet North and 667.11 feet East of the SW corner of the SE 1/4 of Section 34, Township 38 South, Range 19 East; thence run N 00°16'58" W 654.73 feet to a concrete monument for a Point of Beginning; thence continue N 00°16'58" W 654.73; thence run East 665.32 feet; thence run S 00°16'58" E 654.73 feet to a concrete monument; thence run West 665.32 feet to the Point of Beginning. All lying and being in the West 1/2 of the East 1/2 of Section 34, Township 38 South, Range 19 East.

Together with a non-exclusive access easement, 30 feet wide, for ingress and egress across the land described as follows:

Begin at a point on the Section line lying 667.11 feet East of the SW corner of the SE 1/4 of Section 34, Township 38 South, Range 19 East for a Point of Beginning; thence North 100 feet; thence N 00°16'58" W 694.73 feet; thence West 30 feet; thence S 00°16'58" E 694.73 feet; thence South 100 feet; thence East 30 feet to the Point of Beginning.

PARCEL 8:

The West 1/2 of the East 1/2 of Section 34, Township 38 South, Range 19 East, Less tracts described in Official Records Book 1035, Page 1096, Official Records Book 1037, Page 1561, Official Records Book 1075, Page 876 and Official Records Book 1185, Page 1809, of the Public Records of Sarasota County, Florida.

Also being more particularly described as follows:

Begin at the NW corner of the NE 1/4 of Section 34, Township 38 South, Range 19 East; thence N 89°34'05" E 1359.48 feet along the North line of said Section 34 to the NE corner of NW 1/4 of NE 1/4 of said Section 34; thence S 00°10'46" E 2664.93 feet along the East line of the West 1/2 of East 1/2 of said Section 34; thence continue along said East line S 00°10'44" E 1183.64 feet to the NE corner of tract described in Official Records Book 1075, Page 876; thence N 89°52'24" W 665.32 feet to the NE corner of said tract; thence S 00°10'44" E 1409.46 feet along the West line of said property and tract described in Official Records Book 1035, Page 1096 and tract described in Official Records Book 1165, Page 1809; to South line of said Section 34; Thence N 89°52'24" W 666.71 feet along said South line to the SW corner of East 1/2 of said Section 34; thence N 00°28'38" W 5265.49 feet along West line of East 1/2 of said Section 34 to the Point of Beginning.

Less and except Border Road and Laurel Road rights of way.

Less and except the additional right of way for Border Road conveyed to Sarasota County in Official Records Instrument No. 2004032618.

Less and except the lands conveyed to the City of Venice recorded in Official Records Instrument No. 2006171348.

AND

A PORTION OF LAND IN SECTION 34, TOWNSHIP 38 SOUTH, RANGE 19 EAST, SARASOTA COUNTY, FLORIDA, BEING MORE PARTICULARLY DESCRIBED AS FOLLOWS:

BEGINNING AT THE SOUTHWEST CORNER OF FIORE, A SUBDIVISION RECORDED AS PLAT BOOK 55, PAGE 249 OF THE SARASOTA COUNTY RECORDS (FIORE), ALSO BEING THE NORTHWEST CORNER OF ARIA, A SUBDIVISION RECORDED AS PLAT BOOK 52, PAGE 428 OF SARASOTA COUNTY RECORDS (ARIA);

THENCE NORTH 0°01'38" EAST, 318.40 FEET ALONG THE WEST LINE OF SAID FIORE SUBDIVISION TO THE NORTHWEST CORNER OF TRACT 321, FIORE;

THENCE DEPARTING SAID WEST LINE AND ALONG THE NORTHERLY, EASTERLY AND SOUTHERLY LINES OF SAID TRACT 321 THE FOLLOWING TWENTY-TWO (22) COURSES:

- 1) NORTH 68°40'34" EAST, 58.64 FEET;
- 2) SOUTH 65°35'02" EAST, 25.15 FEET;
- 3) NORTH 62°38'08" EAST, 24.30 FEET;
- 4) NORTH 14°37'44" WEST, 15.26 FEET;
- 5) NORTH 3°41'33" WEST, 6.25 FEET;
- 6) NORTH 84°22'40" EAST, 43.17 FEET;
- 7) SOUTH 88°14'14" EAST, 75.55 FEET;
- 8) SOUTH 63°25'24" EAST, 39.01 FEET;
- 9) SOUTH 73°13'24" EAST, 39.01 FEET;
- 10) NORTH 89°28'33" EAST, 18.44 FEET;
- 11) SOUTH 65°23'00" EAST, 87.15 FEET;
- 12) SOUTH 49°27'37" EAST, 44.82 FEET;
- 13) SOUTH 26°06'08" EAST, 11.80 FEET;
- 14) SOUTH 36°12'27" EAST, 49.65 FEET;
- 15) SOUTH 22°40'07" EAST, 50.82 FEET;
- 16) SOUTH 89°56'51" WEST, 44.13 FEET;
- 17) SOUTH 0°03'09" EAST, 20.00 FEET;
- 18) NORTH 89°56'51" EAST, 47.05 FEET;
- 19) SOUTH 9°07'48" EAST, 28.31 FEET;
- 20) SOUTH 4°24'32" WEST, 49.65 FEET;
- 21) SOUTH 26°21'55" EAST, 31.24 FEET;
- 22) SOUTH 16°40'15" WEST, 52.74 FEET TO THE SOUTHEAST CORNER OF SAID TRACT 321;

THENCE SOUTH 89°30'15" EAST, 260.72 FEET ALONG THE SOUTHERLY LINE OF FIORE TO THE SOUTHWEST CORNER OF TRACT 320, FIORE;

THENCE ALONG THE WESTERLY, NORTHERLY AND EASTERLY LINES OF SAID TRACT 320 THE FOLLOWING SIXTEEN (16) COURSES:

- 1) NORTH 73°28'13" EAST, 11.69 FEET;
- 2) NORTH 4°21'02" WEST, 18.00 FEET;
- 3) NORTH 20°12'41" EAST, 38.29 FEET;
- 4) NORTH 9°02'37" WEST, 40.26 FEET;
- 5) NORTH 6°23'30" WEST, 76.76 FEET;
- 6) NORTH 27°21'34" WEST, 145.97 FEET;
- 7) NORTH 0°26'06" WEST, 82.01 FEET;
- 8) NORTH 37°29'41" EAST, 15.81 FEET;
- 9) SOUTH 85°51'16" EAST, 61.52 FEET;
- 10) SOUTH 2°12'14" WEST, 67.24 FEET;
- 11) SOUTH 67°37'16" EAST, 38.77 FEET;
- 12) SOUTH 55°15'49" EAST, 87.52 FEET;
- 13) SOUTH 21°53'20" EAST, 56.25 FEET;
- 14) SOUTH 6°34'07" EAST, 39.94 FEET;
- 15) SOUTH 49°37'17" EAST, 98.66 FEET;
- 16) NORTH 39°00'25" EAST, 18.86 FEET;

THENCE DEPARTING SAID NORTHERLY LINE TRACT 321, SOUTH 0°08'44" WEST, 95.62 FEET TO THE SOUTH LINE OF SAID FIORE SUBDIVISION;

THENCE SOUTH 89°30'35" EAST, 97.99 FEET ALONG SAID SOUTH LINE TO THE NORTHEAST CORNER OF TRACT 302, ARIA SUBDIVISION;

THENCE ALONG THE EASTERLY LINE OF SAID TRACT 302 THE FOLLOWING THREE (3) COURSES:

- 1) SOUTH 3°10'58" EAST, 3.88 FEET;
- 2) SOUTH 5°08'24" WEST, 36.95 FEET;
- 3) SOUTH 54°37'40" WEST, 33.28 FEET TO THE NORTHEAST CORNER OF TRACT 602 OF SAID ARIA SUBDIVISION;

THENCE SOUTH 27°52'44" WEST, 36.98 FEET ALONG THE EAST LINE OF SAID TRACT 602 TO THE NORTHEAST CORNER OF TRACT 303, ARIA SUBDIVISION;

THENCE ALONG THE EASTERLY LINE OF SAID TRACT 303 THE FOLLOWING TWO (2) COURSES:

- 1) SOUTH 42°55'28" EAST, 67.72 FEET;
- 2) SOUTH 35°44'39" EAST, 49.94 FEET TO THE EASTERLY CORNER OF SAID TRACT 303;

LEGAL DESCRIPTION

THENCE SOUTH 6°21'33" EAST, 184.58 FEET;

THENCE NORTH 80°07'20" WEST, 340.47 FEET;

THENCE NORTH 51°27'46" WEST, 28.02 FEET;

THENCE NORTH 0°17'59" EAST, 36.84 FEET;

THENCE NORTH 35°25'22" WEST, 29.13 FEET;

THENCE SOUTH 17°34'07" WEST, 26.39 FEET;

THENCE SOUTH 0°11'02" EAST, 47.72 FEET;

THENCE SOUTH 13°54'55" EAST, 46.51 FEET;

THENCE SOUTH 8°25'23" EAST, 23.81 FEET TO THE NORTHERLY LINE OF TRACT 502, ARIA SUBDIVISION;

THENCE ALONG SAID NORTHERLY LINE TRACT 502 THE FOLLOWING THIRTEEN (13) COURSES:

- 1) NORTH 88°56'48" WEST, 30.75 FEET;
- 2) SOUTH 48°22'17" WEST, 31.66 FEET;
- 3) SOUTH 83°35'19" WEST, 42.10 FEET;
- 4) NORTH 23°21'53" WEST, 17.15 FEET;
- 5) NORTH 1°06'02" WEST, 63.66 FEET;
- 6) NORTH 0°35'40" EAST, 193.02 FEET;
- 7) NORTH 5°48'24" EAST, 28.59 FEET;
- 8) NORTH 57°55'22" WEST, 21.47 FEET;
- 9) SOUTH 48°11'18" WEST, 19.32 FEET;
- 10) SOUTH 0°01'06" EAST, 217.44 FEET;
- 11) SOUTH 28°51'35" WEST, 64.30 FEET;
- 12) NORTH 85°21'25" WEST, 369.24 FEET;
- 13) SOUTH 83°20'28" WEST, 151.31 FEET;

THENCE DEPARTING SAID NORTHERLY LINE TRACT 502, NORTH 17°17'51" EAST, 289.69 FEET;

THENCE SOUTH 86°12'32" WEST, 21.44 FEET;

THENCE SOUTH 17°17'51" WEST, 288.58 FEET TO THE NORTHERLY LINE OF TRACT 604;

THENCE CONTINUE SOUTH 17°17'51" WEST, 8.73 FEET;

THENCE SOUTH 0°24'10" WEST, 64.09 FEET;

THENCE SOUTH 1°09'16" WEST, 79.00 FEET;

THENCE SOUTH 0°48'05" WEST, 73.32 FEET;

THENCE SOUTH 1°18'59" WEST, 56.87 FEET;

THENCE SOUTH 2°55'55" WEST, 57.42 FEET;

THENCE SOUTH 4°04'47" WEST, 52.66 FEET;

THENCE SOUTH 7°28'17" WEST, 51.71 FEET;

THENCE SOUTH 4°47'03" EAST, 63.29 FEET;

THENCE SOUTH 6°01'34" EAST, 56.88 FEET;

THENCE SOUTH 15°25'11" EAST, 48.81 FEET;

THENCE SOUTH 33°54'21" EAST, 55.72 FEET;

THENCE SOUTH 46°03'38" EAST, 51.78 FEET;

THENCE SOUTH 47°50'33" EAST, 35.29 FEET;

THENCE SOUTH 28°50'05" EAST, 58.37 FEET;

THENCE SOUTH 0°05'59" WEST, 338.36 FEET TO A CURVE TO THE LEFT, HAVING A RADIUS OF 20.00 FEET, AND WHOSE CHORD BEARS SOUTH 21°55'27" EAST, 15.00 FEET;

THENCE SOUTHEASTERLY 15.38 FEET ALONG LAST SAID CURVE THROUGH A CENTRAL ANGLE OF 44°02'51";

THENCE SOUTH 0°19'37" WEST, 218.29 FEET TO A NON-TANGENTIAL CURVE TO THE LEFT, HAVING A RADIUS OF 195.00 FEET AND WHOSE CHORD BEARS SOUTH 11°08'01" WEST, 75.09 FEET;

THENCE SOUTHERLY 75.56 FEET ALONG LAST SAID CURVE THROUGH A CENTRAL ANGLE OF 22°12'04";

THENCE SOUTH 0°01'59" WEST, 2,065.27 FEET TO A NON-TANGENTIAL CURVE TO THE LEFT, HAVING A RADIUS OF 20.00 FEET AND WHOSE CHORD BEARS SOUTH 19°18'31" WEST, 13.32 FEET;

THENCE SOUTHERLY 13.57 FEET ALONG LAST SAID CURVE THROUGH A CENTRAL ANGLE OF 38°53'19";

THENCE SOUTH 0°08'09" EAST, 170.61 FEET;

THENCE SOUTH 89°51'15" WEST, 152.82 FEET ALONG A LINE 30.00 FEET NORTHERLY OF AND PARALLEL WITH THE SOUTHERLY LINE OF ARIA SUBDIVISION TO THE WEST LINE OF SAID ARIA SUBDIVISION;

THENCE NORTH 0°01'38" EAST, 4,001.15 FEET ALONG SAID WEST LINE OF ARIA TO THE POINT OF BEGINNING.

CONTAINING 24.106 ACRES, MORE OR LESS.