

MILANO

PLANNED UNIT DEVELOPMENT (PUD)
BINDING MASTER PLAN AMENDMENT

July 3~~April 4~~~~November 16~~, 20223

ADOPTED BY ORDINANCE NO. 20223-11

_____, 20223

MILANO PUD AMENDMENT

PROJECT NARRATIVE

The Milano PUD is ~~528~~ 503.9 +/- acre property located south of Laurel Road, north of Border Road, and bisected by the Jacaranda Boulevard Extension. The property is located within the Northeast Neighborhood of the Comprehensive Plan and has a Future Land Use Designation of Mixed Use Residential (MUR). The Milano PUD approved by Ordinance No. 2017-25 is a residential community consisting of detached single-family homes, paired villas, multi-family homes, amenity centers and open space. The density approved for the Milano PUD is up to 1,350 dwelling units.

The Milano PUD was amended by Ordinance No. 2020-40, which approved revisions to the PUD binding master plan which were all located within the approximately 36 acre development pod at the northwest corner of the Milano PUD, and were limited to the addition of one access point along Laurel Road and the restriction of the existing access point to egress only, the addition of project signage at the new access point, the addition of lot standards for townhomes, a modification of driveway standards for townhomes, the addition of an Amenity Area, the addition of alternative roadway sections to allow for on street parking, and minor modifications to conceptual stormwater pond configurations.

~~The Milano PUD was amended by Ordinance No. 2022-23. This proposed amendment is limited to the removal of 24.1 acres of open space along the western boundary of the Milano PUD, an area of open space which will be added to the adjacent GCCF PUD and will remain open space within the GCCF PUD. Removal of the open space will reduce the Milano PUD acreage to 503.9 acres, the minimum 50% open space within the Milano PUD will be maintained and/or exceeded. No other changes are/were proposed with this/the amendment.~~

This amendment to the Milano PUD proposes to re-designate a 10.42-acre parcel at the southwest corner of the Jacaranda Boulevard and Laurel Road, within the Milano PUD, from Open Space to Commercial, to add access points for the Commercial parcel and establish development standards for the Commercial parcel. The proposed Commercial designated parcel will allow for the provision of limited retail and service uses to meet the needs of the residents of the PUD while reducing trip lengths and increasing multi-modal accessibility to such services for the residents. The PUD requirement for a minimum of 50% Open Space will continue to be maintained.

All internal roadways will be privately owned and maintained. The on-site storm water management system will be privately owned and maintained. Water and wastewater facilities will be dedicated to the City of Venice.

COMPLIANCE

The proposed amendment to the Milano PUD plan remains consistent with all applicable elements of the City's updated 2017 Comprehensive Plan. Specifically, the proposed amendment to the Milano PUD is consistent with *Land Use Element and Northeast Neighborhood Element Strategies LU 1.2.16, LU 1.2.17, and LU NE 1.1.1.A and C.*, with respect to density and open space, and with *Open Space Element Intents OS 1.1, OS1.2, OS 1.3, OS1.4, OS 1.5 and OS 1.6* with respect to open space uses, wetlands, native habitats and open space corridors, and with *Land Use Element Intent LU 4.1.*, with respect to transitional strategies related to compatibility, and development standards.

Finally, the proposed Milano PUD is in compliance with the City of Venice Land Development Code Sec. 86-130 requirements for Planned Unit Development (PUD) Districts as outlined in the below Land Use and Development Standards.

LAND USE AND DEVELOPMENT STANDARDS

The following identifies the proposed development standards for the Milano Planned Unit Development. In furtherance of the interpretation authority granted by the City of Venice Comprehensive Plan and Land Development Code, the Zoning Administrator shall have authority to administratively approve minor modifications of standards contained with the Milano Planned Unit Development, excluding standards related to density, building height, buffer widths, and the addition of permitted uses. Reasonable mitigation measures may be imposed by the Zoning Administrator to limit impacts from the requested adjustment of standards. Where the PUD master plan identifies areas for residential uses, the developer shall have the option to convert such residential use areas to open space uses.

Any standard not stated or otherwise addressed in the binding master plan is subject to Section 86-130, City of Venice PUD standards.

A. Land Uses

1) Permitted Principal Uses and Structures

- Residential single-family dwellings (detached)
- Residential single-family dwellings (attached)
- Townhomes
- Multi-family dwellings
- Private club, community centers and civic and social organization facilities
- Recreational areas
- Open Space
- Convenience stores
- Grocery stores
- Pharmacies
- Produce markets
- Bakeries
- Florists
- Gift shops
- Liquor Stores

- Hair and beauty care and other similar services
- Pet grooming
- Health spas
- Clothing repair and alteration
- Dry cleaning/laundry services
- Studios for instruction in dance, music, yoga, cheer/gymnastics and fitness
- Professional and business offices, medical and dental clinics
- Banks and financial institutions
- Restaurants

2) Permitted accessory uses and structures

- Are customarily accessory and clearly incidental and subordinate to permitted or permissible uses and structures.
- Are located on the same lot as the permitted or permissible use or structure or on a contiguous lot in the same ownership.
- Do not involve operations or structures not in keeping with the character of the district.
- Do not involve the conduct of business on residential premises, provided that accessory home occupations shall be allowed as accessory to residential uses.

B. Density/ Intensity

- 1) Residential- Up to 1,350 residential units
- 2) Commercial - ~~None~~ Maximum 10.42 acres
 - Maximum 0.5 FAR
 - No single use retail in excess of 65,000 square feet
 - Total square footage limited to 70,240 square feet
- 3) Open Space- Minimum 50%

C. Maximum Height of Structures- 3 stories up to 42' including parking.

D. LOT DETAIL

1) Single-Family Detached

- Minimum Lot Size: 4,500 square feet
- Maximum Lot Coverage: None, except as required to meet other requirements set out in this section
- Lot Width: 40 feet
- Front Yard: 20 feet, or 15 feet when building has side entry garage
- Side Yard: 5 feet
- Rear Yard: 10 feet
- Accessory structures/appurtenant structures including, but not limited to pool cages, may be located within five feet of the rear lot line

2) Single-Family Attached (Paired Villas)

- Minimum Lot Size: 4,140 square feet
- Maximum Lot Coverage: None, except as required to meet other requirements set out in this section
- Lot Width: 36 feet
- Front Yard: 20 feet
- Side Yard: 5 feet
- Rear Yard: 10 feet
- Accessory structures/appurtenant structures including, but not limited to pool cages, may be located within five feet of the rear lot line

3) Townhomes

- Minimum Lot Size: 1,800 square feet
- Maximum Lot Coverage: None, except as required to meet other requirements set out in this section
- Lot Width: 18 feet
- Front Yard: 20 feet
- Side Yard: none
- Rear Yard: 10 feet
- Accessory structures/appurtenant structures including, but not limited to pool cages, may be located within five feet of the rear lot line

4) Multi-Family

- Minimum Lot Size: 10,400 square feet
- Maximum Lot Coverage: None, except as required to meet other requirements as set out in this section
- Lot Width: 130 feet
- Front Yard: 20 feet
- Side Yard: 5 feet
- Rear Yard: 10 feet
- Accessory structures/appurtenant structures including, but not limited to pool cages, may be located within five feet of the rear lot line

5) Commercial

- Minimum Lot Size: None, except as required to meet other requirements as set out in this section
- Maximum Lot Coverage: None, except as required to meet other requirements as set out in this section
- Lot Width: None, except as required to meet other requirements as set out in this section
- Front Yard: 10 feet
- Side Yard: None

- Rear Yard: 10 feet

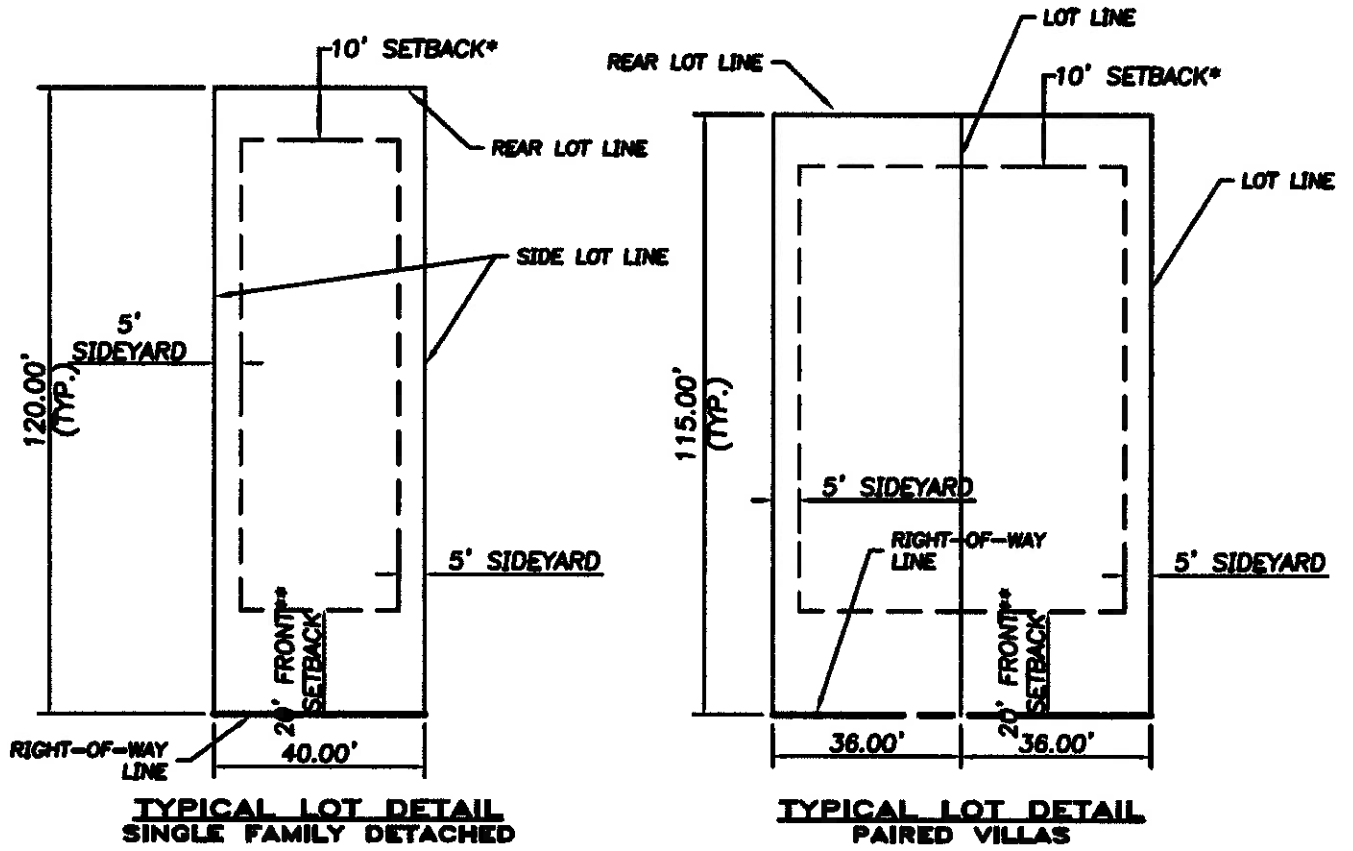

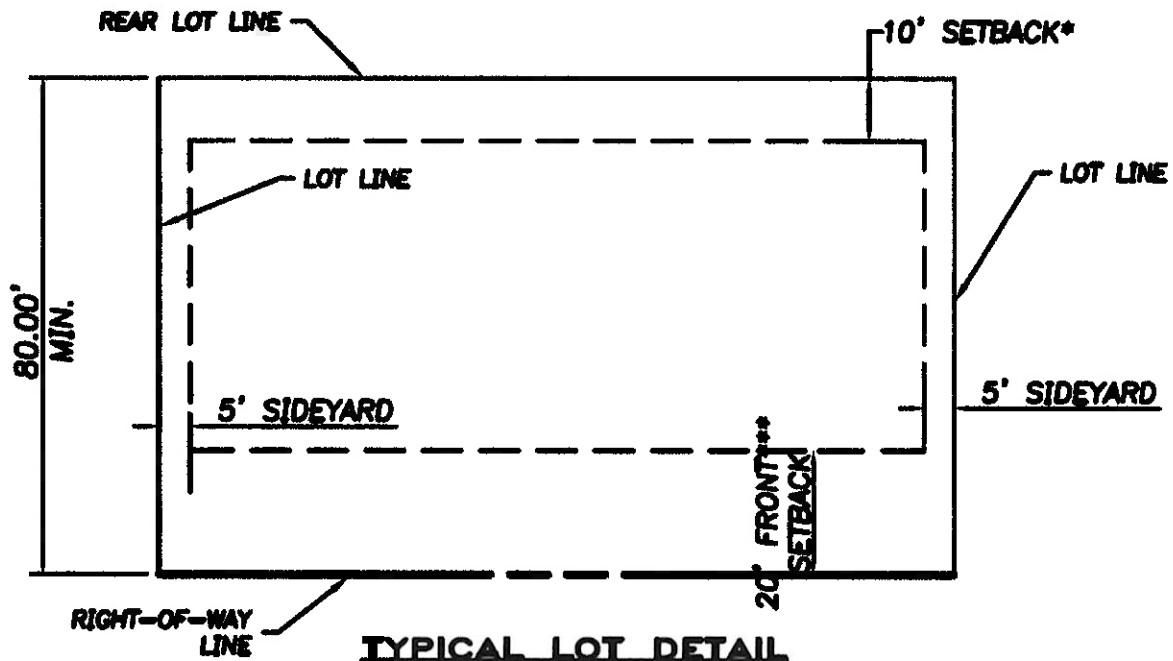

TYPICAL LOT DETAIL
4 PLEX/6 PLEX

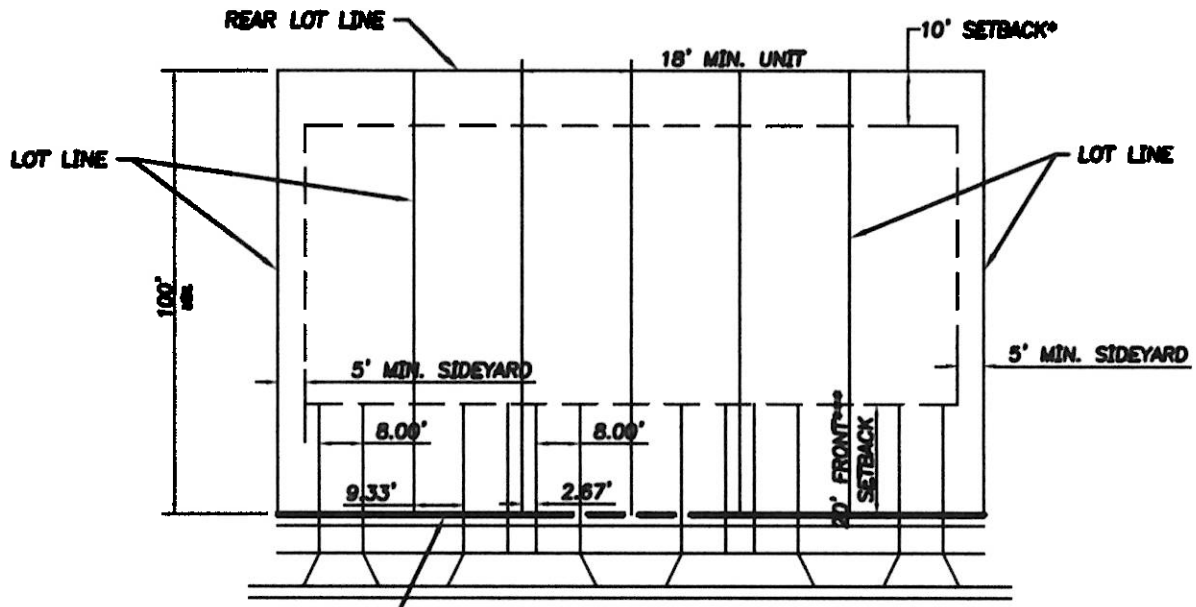

TYPICAL LOT DETAIL
4/6 UNIT TOWNHOME
BUILDING

*ACCESSORY STRUCTURES/APPURTENANT STRUCTURES SUCH AS POOL CAGES, MAY BE LOCATED WITHIN FIVE FEET OF THE REAR LOT LINE.

**FRONT SETBACK MAY BE REDUCED TO 15' WHEN THE BUILDING HAS A SIDE ENTRY GARAGE

***SETBACKS ARE MINIMUMS AND MAY BE EXCEEDED WHERE NECESSARY

E. BUFFERS/ LANDSCAPING

RESIDENTIAL

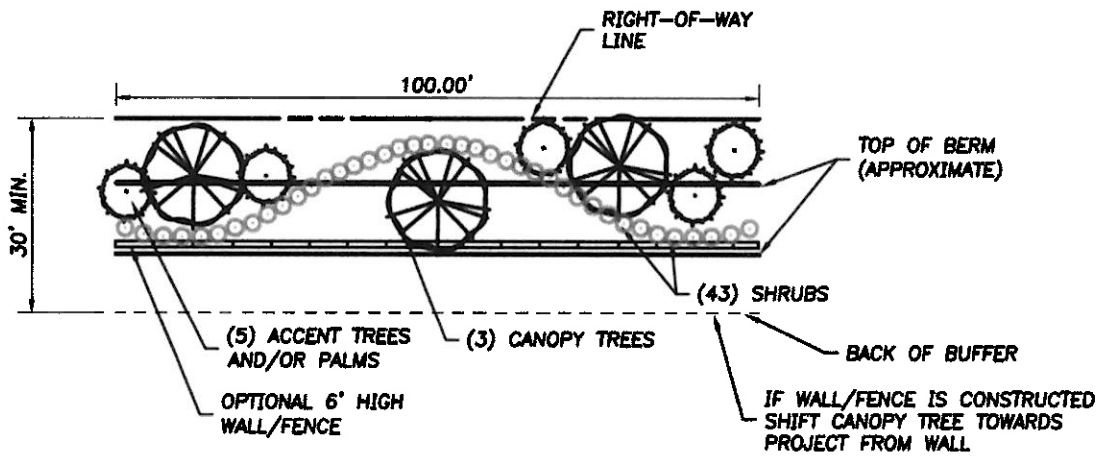

JACARANDA BOULEVARD TYPICAL BUFFER

NOTES:

PLANT MATERIAL AND WALL LOCATION DEPENDS ON EXISTING SARASOTA COUNTY UTILITIES LOCATIONS BERM CONSTRUCTION RESTRICTIONS PER SARASOTA COUNTY UTILITY DEPARTMENT.

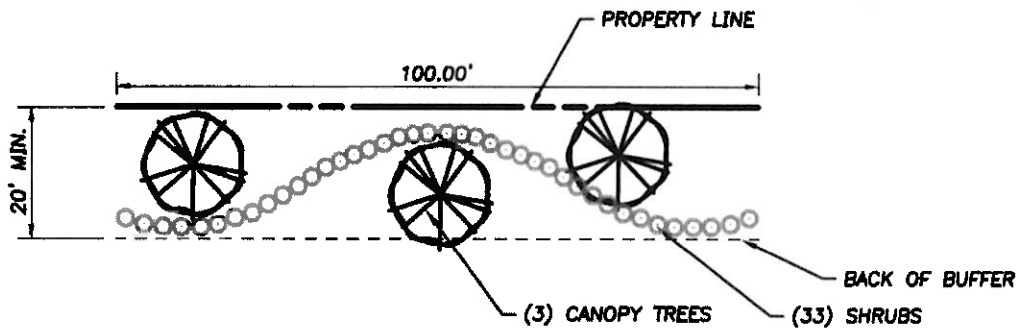

EAST PROPERTY LINE TYPICAL BUFFER

NOTES:

1. EXISTING VEGETATION TO REMAIN WHERE FEASIBLE TO SATISFY BUFFER PLANTING REQUIREMENTS
2. TYPICAL BUFFER REQUIREMENTS WILL NOT APPLY WHERE EXISTING WETLANDS ARE TO REMAIN.

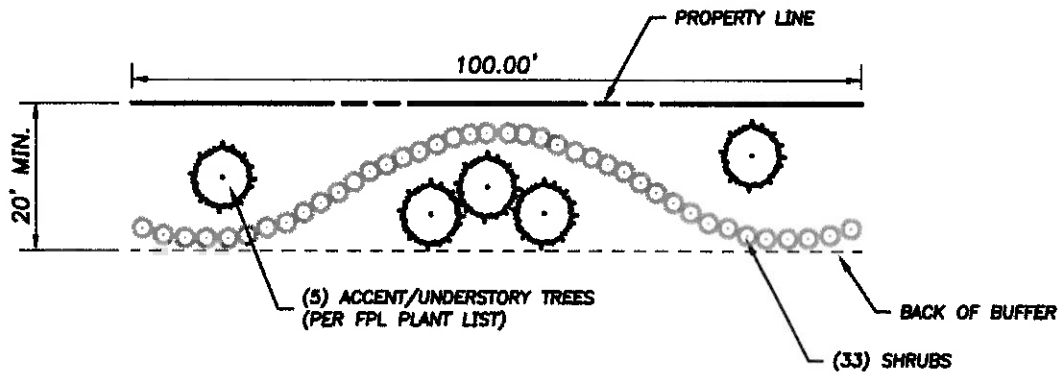

WEST PROPERTY LINE BUFFER (TYPE A)(FPL EASEMENT)

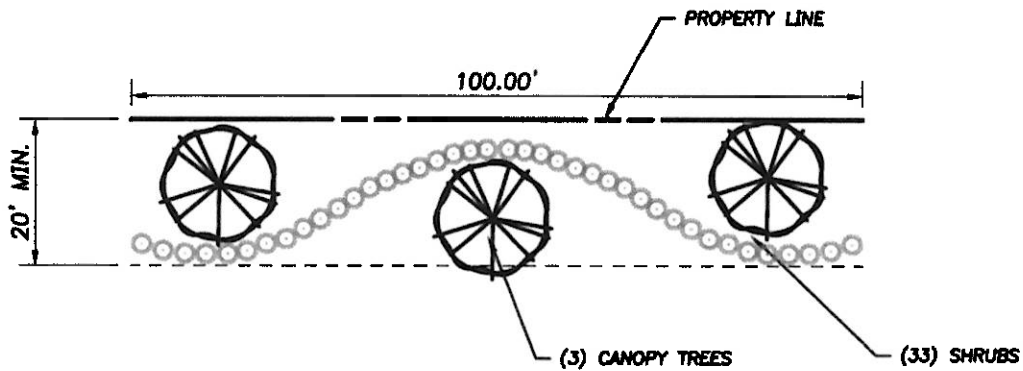

WEST PROPERTY LINE BUFFER (TYPE B)(NO FPL EASEMENT)

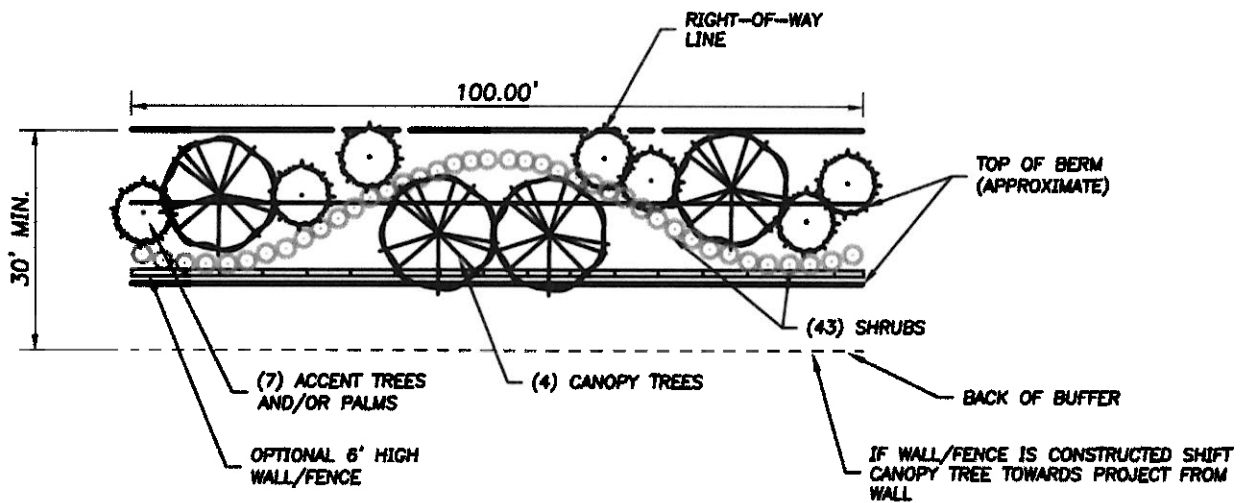

LAUREL ROAD AND BORDER ROAD TYPICAL BUFFER (60% OPACITY)
(TYPE C)– WITH FPL CONFLICT

NOTES:

1. EXISTING VEGETATION TO REMAIN WHERE FEASIBLE TO SATISFY BUFFER PLANTING REQUIREMENTS
2. TYPICAL BUFFER REQUIREMENTS WILL NOT APPLY WHERE EXISTING WETLANDS ARE TO REMAIN.
3. WHERE OVERHEAD UTILITY POLE LOCATIONS RESTRICT VERTICAL VEGETATION HEIGHTS, ACCENT TRESS AS DEFINED BY SARASOTA COUNTY SHALL BE USED IN LIEU OF A CANOPY TREE.

COMMERCIAL

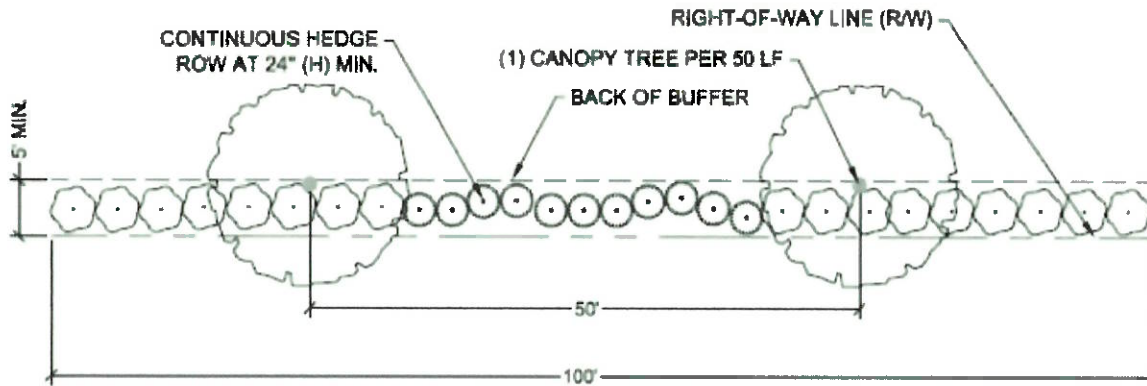

Laurel Road and Jacaranda Boulevard Typical Buffer

NOTES:

1. PLANT MATERIAL SPECIES AND LOCATION DEPENDS ON EXISTING UTILITY LOCATIONS.
2. AN OPAQUE WALL CAN BE USED IN LIEU OF A CONTINUOUS HEDGE. IF A WALL IS TO BE UTILIZED ONE SHRUB/VINE PER 10 LINEAR FEET SHALL BE PLANTED. THESE SHRUBS/VINES SHALL NOT BE PLANTED EVERY 10 FEET.
3. SHRUBS/VINES SHALL BE PLANTED STREET SIDE UNLESS THEY ARE OF SUFFICIENT HEIGHT AT THE TIME OF PLANTING.
4. THE REMAINDER OF THE BARRIER SHALL BE LANDSCAPED WITH GRASS, GROUND COVER OR OTHER LANDSCAPE TREATMENT.

F. Roadway Design

- 1) The Milano PUD proposes an alternative neighborhood roadway design with the following standards (see typical roadway section below):
 - Right-of-Way: 43 feet
 - Travel Lanes: 10 feet
 - Sidewalk: 5 feet, one side of street only
 - 2 foot curb
 - One (1) tree per lot which may be placed within or adjacent to the ROW, minimum 3" caliper at installation

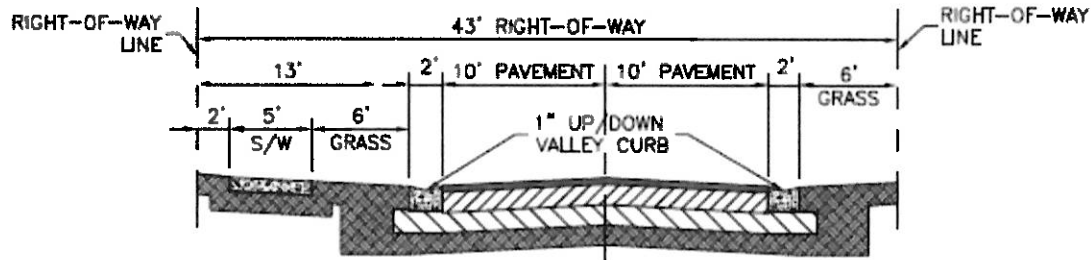

TYPICAL NEIGHBORHOOD ROADWAY SECTION

NOTES:

1. ALL PRIVATE LOCAL STREET RIGHT OF WAYS TO BE INGRESS/EGRESS, UTILITY AND DRAINAGE EASEMENTS, AND PUBLIC UTILITY EASEMENTS.
 2. NO UTILITY SERVICES IN SIDEWALK.
 3. THERE SHALL BE NO ON-STREET PARKING PERMITTED.
- 2) Pursuant to Sec. 86-233(3) City Council Approval of dead-end streets (cul-de-sacs) up to 1,200 feet in length is requested.
 - 3) Pursuant to City of Venice Comprehensive Plan, Housing and Neighborhood Development Policy 2.6, City Council approval of limited access gates for neighborhood roads is requested.
 - 4) The Milano PUD proposes the additional alternative roadway design standards for the 36 acre development pod at the northwest corner of the Milano PUD.

ROADWAY SECTIONS

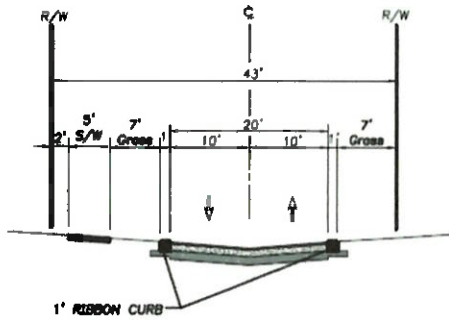

INVERTED CROWN 43' RIGHT-OF-WAY SECTION
20' PAVEMENT
- NO SCALE -

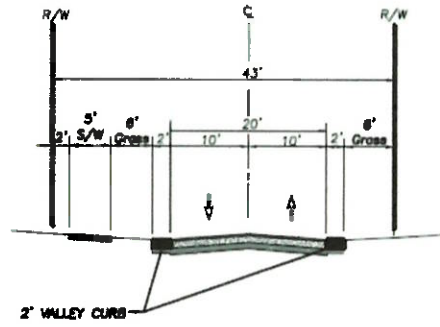

TYPICAL NEIGHBORHOOD ROADWAY SECTION
20' PAVEMENT
- NO SCALE -

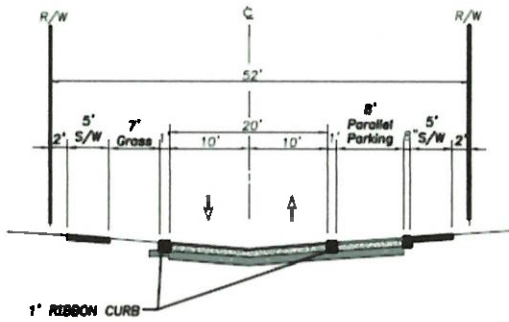

INVERTED CROWN 52' RIGHT-OF-WAY SECTION
PARALLEL PARKING
20' PAVEMENT
- NO SCALE -

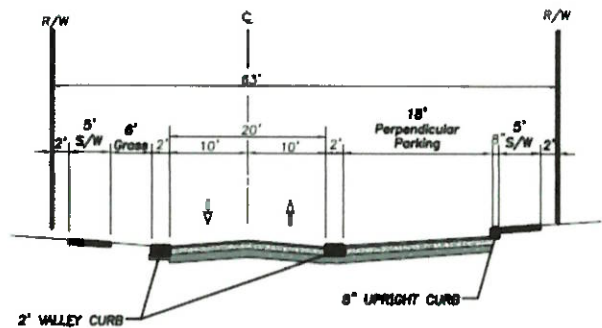

CROWN 63' RIGHT-OF-WAY SECTION
PERPENDICULAR PARKING
20' PAVEMENT
- NO SCALE -

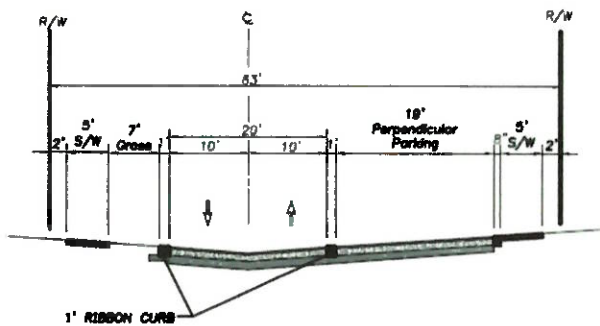

INVERTED CROWN 63' RIGHT-OF-WAY SECTION
PERPENDICULAR PARKING
20' PAVEMENT
- NO SCALE -

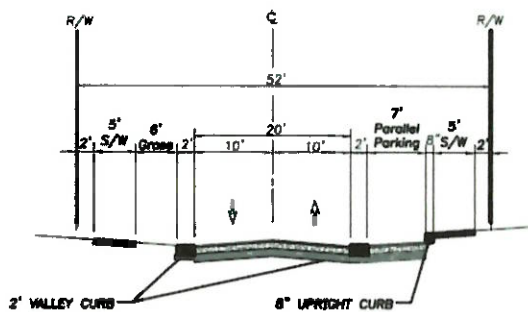

CROWN 52' RIGHT-OF-WAY SECTION
PARALLEL PARKING
20' PAVEMENT
- NO SCALE -

NOTES:

1. ALL PRIVATE LOCAL STREET RIGHT OF WAYS TO BE INGRESS/EGRESS, UTILITY AND DRAINAGE EASEMENTS, AND PUBLIC UTILITY EASEMENTS.
2. NO UTILITY SERVICES IN SIDEWALK.

G. SIGNAGE: No signs are permitted in the Milano PUD except:

RESIDENTIAL

- 1) One non-illuminated temporary construction project ground sign per street frontage, not exceeding 32 square feet in area, such sign not to be erected more than 60 days prior to the time actual construction begins, and to be removed upon completion of actual construction. If construction is not begun within 60 days or if construction is not continuously and actively prosecuted to completion, the sign shall be removed.
- 2) One community identification, monument-style ground sign, not to exceed nine (9) feet in height and twenty (20) feet in width, on each side, or in the median and one side, of each vehicular access point off Laurel Road and Jacaranda Boulevard, including access points at the intersections of Laurel Road and Jacaranda Boulevard, and Border Road and Jacaranda Boulevard.
- 3) One wall or monument-style ground sign, not over eight square feet in area, to identify a private club.

COMMERCIAL

- 1) Monument Ground Sign – one per vehicular access point off Laurel Road and Jacaranda Boulevard, maximum sign face 100 square feet, maximum area of structure including sign face 250 square feet, maximum height 15 feet.
- 2) Building Sign – Single-tenant building 1.5 sq.ft. per linear foot of building frontage OR 150 sq.ft. total, whichever is less.
- 3) Multi-tenant building 1.5 sq.ft. per linear foot of tenant space with public entrance.

H. Architectural Design Standards: Pursuant to City of Venice Comprehensive Plan, Future Land Use and Design Element, Policy 16.18.G.1, the Milano PUD will apply Northern Italian Architectural Design.



Building. Home. Life.

TYPICAL HOUSING STYLES



NEAL COMMUNITIES

BUILDING TODAY'S MOST DESIRED HOMES

PROPOSED MILANO PUD MODIFICATION TO STANDARDS

- 1) A modification to the requirements of Sec. 86-130 (q), concerning the requirement that no structure shall be located closer to any perimeter property line than two times the height of such structure, is requested. The proposed modification is to reduce the required setback from perimeter property lines to one times the building height.

The proposed modification request is justified based upon the low intensity of the development plan, the extensive perimeter buffers and the significant amount of open space otherwise provided.

- 2) A modification to the requirements of Sec 86-232(5) concerning the roadway design standards is proposed and an alternative neighborhood roadway design is proposed. The proposed modification reduces right-of way width from 52' to 43', allows for sidewalks on one side of the neighborhood roadway only, and eliminates bike lanes for the neighborhood roadways.

The proposed modification request is justified based upon the protection of wetlands and their buffers afforded by the modification, the low intensity of the development plan, and the circulation plan which demonstrate sidewalks on one side of the street will provide excellent pedestrian connectivity from each of the development pods to the amenity center and also to the sidewalk and multi-use trail along Jacaranda Boulevard.

- 3) A modification to Sec. 86-130 (h) is requested concerning building height. The proposed modification is to replace the Land Development Code standard of 35' over 10' of parking with the Comprehensive Plan standard of 3 stories up to 42' including parking.

The proposed modification, at the direction of City staff, is necessary to address an inconsistency between the City's Land Development Code and its Comprehensive Plan.

- 4) A modification to Sec. 86-423(b) is requested concerning driveway standards for Townhomes. The proposed modification is to substitute the driveway dimension as depicted on the Typical Lot Detail for Townhomes (Page 67), and to reduce the required minimum distance from the edge of pavement of two intersecting streets from 40 feet to 30 feet.

The proposed modification is justified based upon the width of Townhome lots, and the limited number of driveways which will be located in proximity to the intersection of two streets, and the number of lots that would not meet the 40 foot standard (one lot).

- ~~5) A modification to the requirements of Sec. 86-437. — Landscaping adjacent to property lines is requested to eliminate the requirement for a landscape buffer along the southern boundary of the commercial parcel.~~

~~The proposed modification is justified due the location of the 330 foot wide FPL easement located along the entire southern boundary and the significant amount of remaining vegetation providing a natural buffer within and to the south of the FPL easement between the nearest adjacent residences in excess of 500 feet from the southern boundary.~~

PLANNED UNIT DEVELOPMENT PLANS FOR
MILANO

PART OF SECTION 35, TOWNSHIP 38 SOUTH, RANGE 19 EAST
CITY OF VENICE
SARASOTA COUNTY, FL

A DEVELOPMENT BY
NEAL COMMUNITIES OF SOUTHWEST FLORIDA, LLC
5800 LAKEWOOD RANCH BOULEVARD
SARASOTA, FL 34240
(941) 328-1111

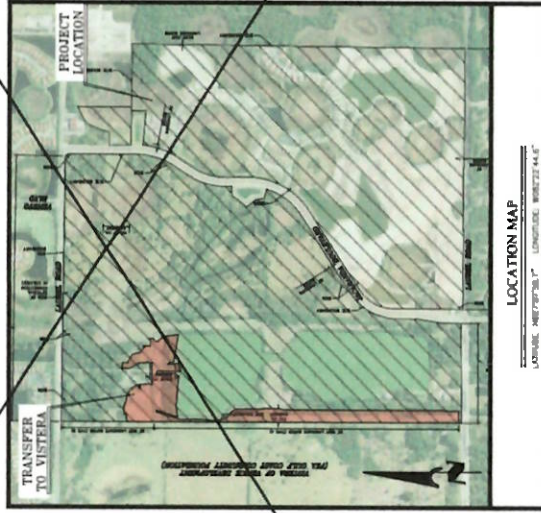

INDEX TO SHEETS

SHEET NO.	DESCRIPTION
1	COVER SHEET
2	MASTER SITE PLAN
3	CIRCULATION PLAN

CALL BEFORE YOU DIG!
SUNSHINE STATE ONE-CALL CENTER
1-800-437-4770
JANUARY 27, 2022 BRC
PUD MODIFICATION

AM ENGINEERING, LLC.
Call Engineering | Local Licensing
5040 Colburn Court, Colorado Springs, CO
Phone: 719.377.9793 | www.amengr.com
CA 93806 | US 41324

NEAL COMMUNITIES OF SOUTHWEST FLORIDA, LLC
MILANO
COVER SHEET

SCALE	1" = 300'
DATE	N/A
PROJECT	N/A
DESIGNER	NEAL COMMUNITIES OF SOUTHWEST FLORIDA, LLC

SEBASTIAN P. COLEMAN, P.E.
LICENSE NO. 10000

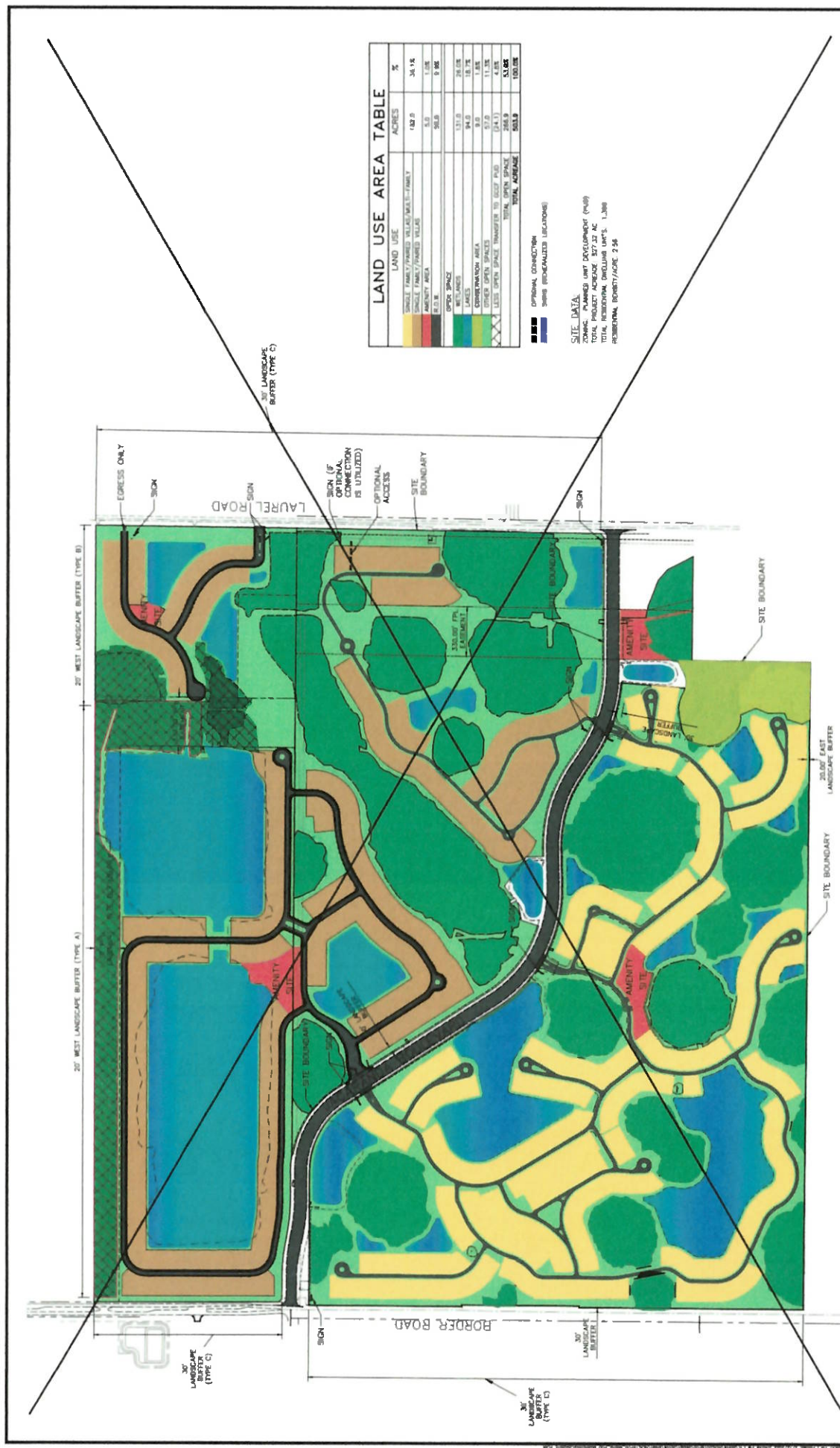

LAND USE AREA TABLE

LAND USE	ACRES	%
SINGLE FAMILY/FORMED VILLAGES/FAMILY	182.0	34.1%
MULTI-FAMILY/FORMED VILLAGES	5.0	1.0%
OPEN SPACE	50.0	9.6%
WETLANDS	131.0	25.0%
LAKES	94.0	18.1%
DEVELOPMENT AREA	9.0	1.7%
LANDSCAPE BUFFER	14.0	2.7%
LANDSCAPE BUFFER TRANSFER TO 0227 PUD	14.1	2.7%
TOTAL OPEN SPACE	268.9	51.6%
TOTAL ACRES	533.9	100.0%

SITE DATA
 ZONING: PLANNED UNIT DEVELOPMENT (PUD)
 TOTAL ACRES: 533.9 AC
 TOTAL RESIDENTIAL DEVELOPABLE UNITS: 1,200
 RESIDENTIAL DENSITY/ACRE: 2.06

CALL BEFORE YOU DIG!
 SUNSHINE STATE ONE-CALL CENTER
 800-432-4770
 JANUARY 27, 2022 BRC
 PUD MODIFICATION

AM ENGINEERING, LLC
 840 Colton Road, Suite 100
 Milpitas, CA 95035
 Phone: (415) 377-9175 | www.amengr.com
 CA 95035 | 650-428-8484

NEAL COMMUNITIES OF
 SOUTHWEST FLORIDA, LLC
 MILANO PUD
 MASTER SITE PLAN

SCALE: 1" = 300'
 N/A
 N/A
 2

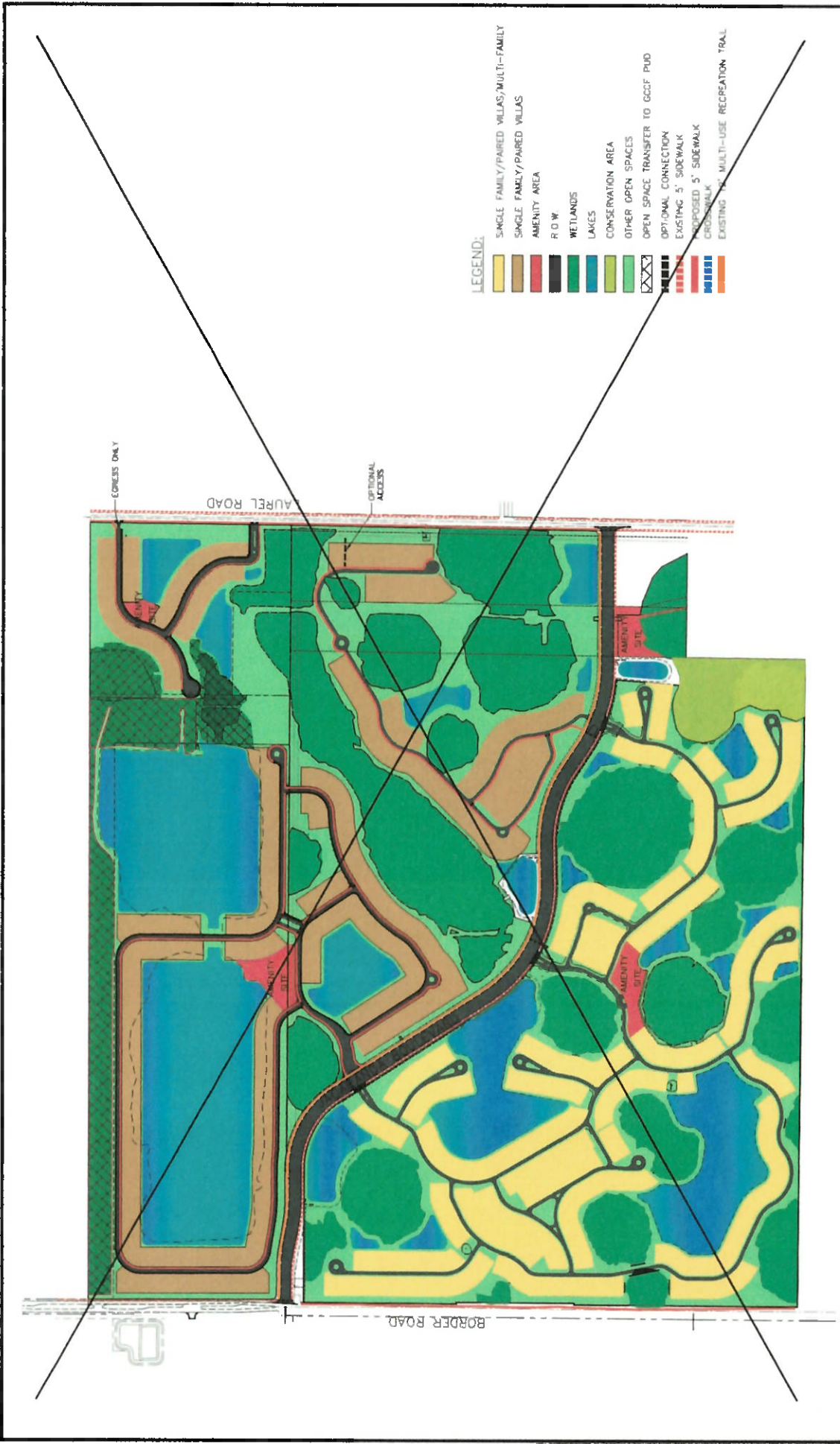

LEGEND:

- SINGLE FAMILY/PAIRED VILLAS/MULTI-FAMILY
- SINGLE FAMILY/PAIRED VILLAS
- AMENITY AREA
- ROW
- WETLANDS
- LAKES
- CONSERVATION AREA
- OTHER OPEN SPACES
- OPEN SPACE TRANSFER TO GCCF PUD
- OPTIONAL CONNECTION
- EXISTING 5' SIDEWALK
- PROPOSED 5' SIDEWALK
- CROSSWALK
- EXISTING MULTI-USE RECREATION TRAIL

	<p>NEAL COMMUNITIES OF SOUTHWEST FLORIDA, LLC</p> <p>MILANO PUD</p> <p>CIRCULATION PLAN</p>	<p>1"=200'</p> <p>N/A</p> <p>N/A</p> <p>NEAL0018PUD</p> <p style="text-align: right;">3</p>
<p>CALL BEFORE YOU DIG!</p> <p>"SUNSHINE STATE ONE-CALL CENTER"</p> <p>1-800-432-4770</p> <p>FOR A LIST OF PARTICIPATING SERVICE PROVIDERS VISIT: www.onecall.com</p> <p>JANUARY 27, 2022</p> <p>PUD MODIFICATION</p>	<p>Call Engineering Land Surveying</p> <p>AM ENGINEERING, LLC</p> <p>15450 Plymouth Road, Suite 200 Plymouth, PA 15773 www.amengr.com CA 13308 814 8434</p>	

PLANNED UNIT DEVELOPMENT PLANS FOR
MILANO

PART OF SECTION 35, TOWNSHIP 38 SOUTH, RANGE 19 EAST
CITY OF VENICE
SARASOTA COUNTY, FL

A DEVELOPMENT BY
NEAL COMMUNITIES OF SOUTHWEST FLORIDA, LLC
5800 LAKEWOOD RANCH BOULEVARD
SARASOTA, FL 34240
(941) 328-1111

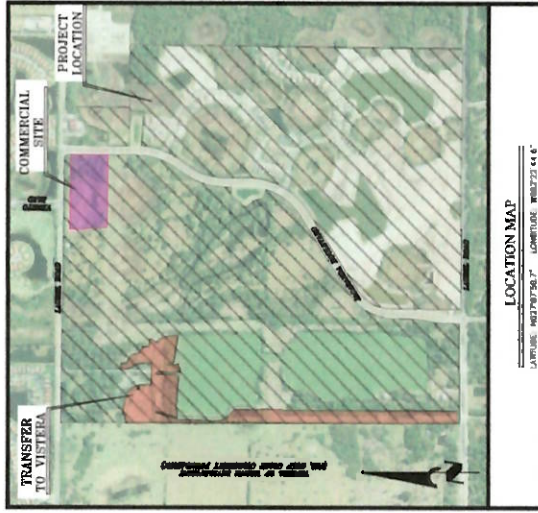

INDEX TO SHEETS

SHEET NO.	DESCRIPTION
1	COVER SHEET
2	MASTER SITE PLAN
3	CIRCULATION PLAN

<p>CALL BEFORE YOU DIG! SUNSHINE STATE ONE-CALL CENTER 1-800-432-4770 FOR A LIST OF PARTICIPATING SERVICE PROVIDERS VISIT WWW.FL1CALL.COM</p> <p>JANUARY 27, 2022 BFC</p> <p>PUD MODIFICATION</p>		<p>ENGINEERING, LLC Civil Engineering & Land Surveying 10000 W. Bay Blvd., Suite 100 Palm Beach Gardens, FL 33418 C-133008 L.P. #4204</p>	<p>NEAL COMMUNITIES OF SOUTHWEST FLORIDA, LLC MILANO</p>	<p>1" = 300'</p> <p>N/A</p> <p>N/A</p> <p>1</p> <p>1</p>	<p>Bobbi Claybrooke</p> <p>Florida Registered Professional Engineer No. 12436 Date: 08/21/18 11/15/22</p>
---	--	---	--	--	---

THIS ITEM HAS BEEN DIGITALLY SIGNED AND SEALED BY BOBBI R. CLAYBROOKE, PE ON 11/16/2022 USING A DIGITAL SIGNATURE. PRINTED COPIES OF THIS DOCUMENT ARE NOT CONSIDERED SIGNED AND SEALED AND THE SHA AUTHENTICATION CODE MUST BE VERIFIED ON ANY ELECTRONIC COPIES.



LAND USE AREA TABLE

LAND USE	ACRES	%
SINGLE FAMILY/PARMIER WELLS/FAMILY	180.0	36.1%
SINGLE FAMILY/PARMIER WELLS	8.0	1.6%
COMMERCIAL SITE	10.4	2.1%
R.O.W.	50.0	10.0%
OPEN SPACE	122.2	24.4%
WETLANDS	63.3	12.7%
WATER	63.3	12.7%
LANDS TO BE REMOVED	2.0	0.4%
LANDS TO BE TRANSFERRED TO GOVT PUD	24.1	4.8%
TOTAL OPEN SPACE	266.5	53.3%
TOTAL ACRES	500.9	100.0%

SITE DATA:
 ZONING: PLANNED UNIT DEVELOPMENT (PUD)
 TOTAL PROJECT ACRES: 500.9 AC
 TOTAL DEVELOPABLE ACRES: 11.36
 RESIDENTIAL DENSITY/ACRE: 2.88

CALL BEFORE YOU DIG! SUNSHINE STATE ONE-CALL CENTER 1-800-432-4773 (FOR A LIST OF PARTICIPATING UTILITIES VISIT WWW.CALLBEFOREYODIG.COM)		Call Engineering Land Surveying ENGINEERING, LLC. 10000 S. Orange Blossom Trail, Suite 100 Orange, FL 32715 CA #13486 LS #4334		NEAL COMMUNITIES OF SOUTHWEST FLORIDA, LLC MILANO PUD MASTER SITE PLAN	
JANUARY 27, 2022 PUD MODIFICATION		Scale: 1" = 300' N/A N/A NEAL/OT/EP/D		SHEET NO. 2	
PROJECT NO. 2022-001 DATE: 01/27/2022 DRAWN BY: [Name] CHECKED BY: [Name]		PROJECT NO. 2022-001 DATE: 01/27/2022 DRAWN BY: [Name] CHECKED BY: [Name]		PROJECT NO. 2022-001 DATE: 01/27/2022 DRAWN BY: [Name] CHECKED BY: [Name]	

THIS ITEM HAS BEEN DIGITALLY SIGNED AND SEALED BY BOBBY R. CLAYBROOKE, PE ON 11/16/2022 USING A DIGITAL SIGNATURE. PRINTED COPIES OF THIS DOCUMENT ARE NOT CONSIDERED SIGNED AND SEALED AND THE SHA AUTHENTICATION CODE MUST BE VERIFIED ON ANY ELECTRONIC COPIES.

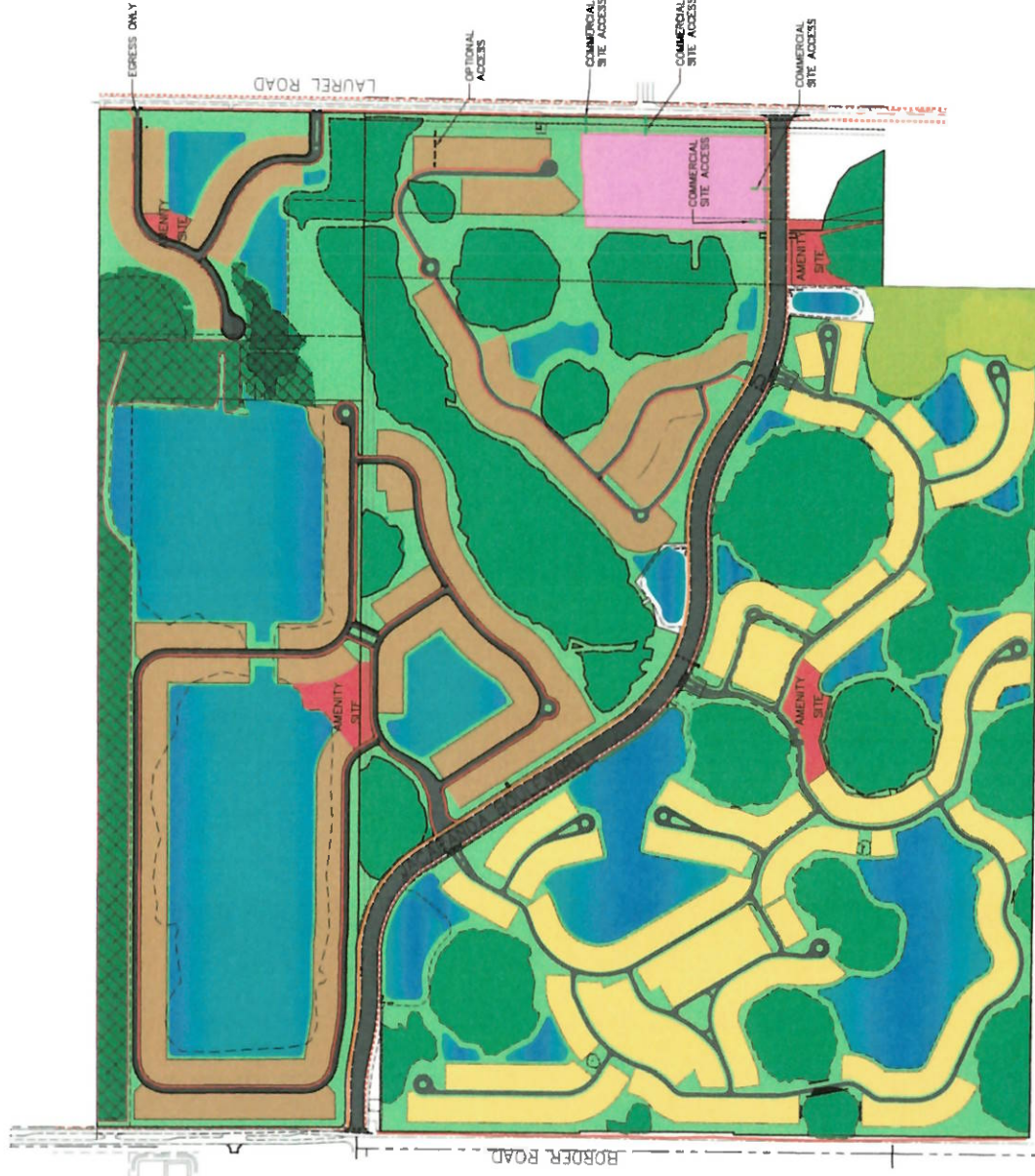

LEGEND:

- SINGLE FAMILY/PAIRED VILAS/MULTI-FAMILY
- SINGLE FAMILY/PAIRED VILAS
- AMENITY AREA
- COMMERCIAL SITE
- R O W
- WETLANDS
- LAKES
- CONSERVATION AREA
- OTHER OPEN SPACES
- OPEN SPACE TRANSFER TO GOLF PUD
- OPTIONAL CONNECTION
- EXISTING 5' SIDEWALK
- PROPOSED 5' SIDEWALK
- CROSSWALK
- EXISTING 12' MULTI-USE RECREATION TRAIL
- COMMERCIAL ACCESS

<p>CALL BEFORE YOU DIG! SUNSHINE STATE ONE-CALL CENTER 1-800-432-4773 (FOR A LIST OF PARTICIPATING SERVICE PROVIDERS, VISIT WWW.SUNSHINESTATEONECALL.COM)</p>		<p>Call Engineering Land Surveying ENGINEERING, LLC. 8040 Central Expressway, Suite 200 San Diego, CA 92121 CA 23196 619 424-8204</p>		<p>NEAL COMMUNITIES OF SOUTHWEST FLORIDA, LLC MILANO PUD</p>		<p>1" = 300' N/A N/A NEAL001EPUD 3</p>	
<p>JANUARY 27, 2022 PUD MODIFICATION</p>		<p>SCALE IN FEET 0 150 300 450 600</p>		<p>CIRCULATION PLAN</p>			
<p>DATE: 1/27/2022 RESPONSE TO CITY COMMENTS: SHEET NO. 10 OF 10 PROJECT NO. 2021-001</p>		<p>DATE: 1/27/2022 RESPONSE TO CITY COMMENTS: SHEET NO. 10 OF 10 PROJECT NO. 2021-001</p>		<p>DATE: 1/27/2022 RESPONSE TO CITY COMMENTS: SHEET NO. 10 OF 10 PROJECT NO. 2021-001</p>		<p>DATE: 1/27/2022 RESPONSE TO CITY COMMENTS: SHEET NO. 10 OF 10 PROJECT NO. 2021-001</p>	

THIS ITEM HAS BEEN DIGITALLY SIGNED AND SEALED BY BOBBY R. CLAYBROOKE, PE ON 1/15/2022 USING A DIGITAL SIGNATURE. PRINTED COPIES OF THIS DOCUMENT ARE NOT CONSIDERED SIGNED AND SEALED AND THE SHA AUTHENTICATION CODE MUST BE VERIFIED ON ANY ELECTRONIC COPIES.