

Prepared by: City Clerk

ORDINANCE NO. 2023-11

AN ORDINANCE OF THE CITY OF VENICE, FLORIDA, GRANTING ZONING MAP AMENDMENT PETITION NO. 22-38RZ FOR THE MILANO PLANNED UNIT DEVELOPMENT (PUD) LOCATED AT LAUREL ROAD AND JACARANDA BOULEVARD, BY CHANGING THE LAND USE DESIGNATION FOR AN APPROXIMATELY 10.42 ACRES PARCEL FROM OPEN SPACE TO COMMERCIAL AND AMENDING THE MILANO PUD BINDING MASTER PLAN (BMP) TO ALLOW FOR COMMERCIAL DEVELOPMENT; PROVIDING FOR REPEAL OF ALL ORDINANCES IN CONFLICT HERewith; PROVIDING FOR SEVERABILITY; AND PROVIDING AN EFFECTIVE DATE

WHEREAS, Zoning Map Amendment Petition No. 22-38RZ requests a change in the land use designation from Open Space to Commercial for an approximately 10.42 acres parcel in the Milano Planned Unit Development (PUD), and an amendment to the Binding Master Plan (BMP) to allow for commercial development; and

WHEREAS, Petition No. 22-38RZ was filed prior to the City's adoption of its new Land Development Regulations on July 12, 2022; and

WHEREAS, land development applications filed prior to July 12, 2022 are subject to the City's previously existing Land Development Code; and

WHEREAS, the subject property has been found to be located within the corporate limits of the City of Venice; and

WHEREAS, the City of Venice Planning Commission has been designated as the local planning agency in accordance with F.S. 163.3174; and

WHEREAS, the Planning Commission held a noticed public hearing beginning on January 17, 2023, which was subsequently continued to February 21, 2023, and then to March 21, 2023 regarding the Petition and, based upon the evidence and testimony received at the public hearing, voted to recommend denial of the Petition; and

WHEREAS, the Venice City Council has received and considered the report of the Planning Commission concerning the Petition; and

WHEREAS, the City Council held a duly noticed public hearing on the Petition in accordance with the requirements of the City's Code of Ordinances, and has considered the evidence and testimony received at said public hearing.

NOW, THEREFORE, BE IT ORDAINED BY THE CITY COUNCIL OF THE CITY OF VENICE, FLORIDA:

SECTION 1. The Whereas clauses above are ratified and confirmed as true and correct.

SECTION 2. The City Council hereby makes the following findings of fact:

A. The Council has received and considered the report of the Planning Commission recommending denial of the Petition.

B. The Council held, after due public notice, a public hearing on the Petition and considered the evidence and testimony received at said public hearing.

C. The proposed PUD amendment for the property described herein is in accordance with and meets the requirements of the Land Development Code (as it existed on July 11, 2022) and is consistent with the City of Venice Comprehensive Plan.

SECTION 3. Zoning Map Amendment Petition No. 22-38RZ is hereby approved, changing the land use designation for an approximately 10.42 acres parcel from Open Space to Commercial in the Milano Planned Unit Development (PUD), and amending the Binding Master Plan (BMP) to allow for commercial development, all as indicated in the Milano Planned Unit Development (PUD) Binding Master Plan (BMP) Amendment dated November 16, 2022, which is attached hereto as Exhibit "A", is hereby adopted and incorporated by reference.

Property Description of Milano PUD Parcel at Issue:

As depicted on the zoning map shown below consisting of 10.42± acres and further described in Exhibit "B".

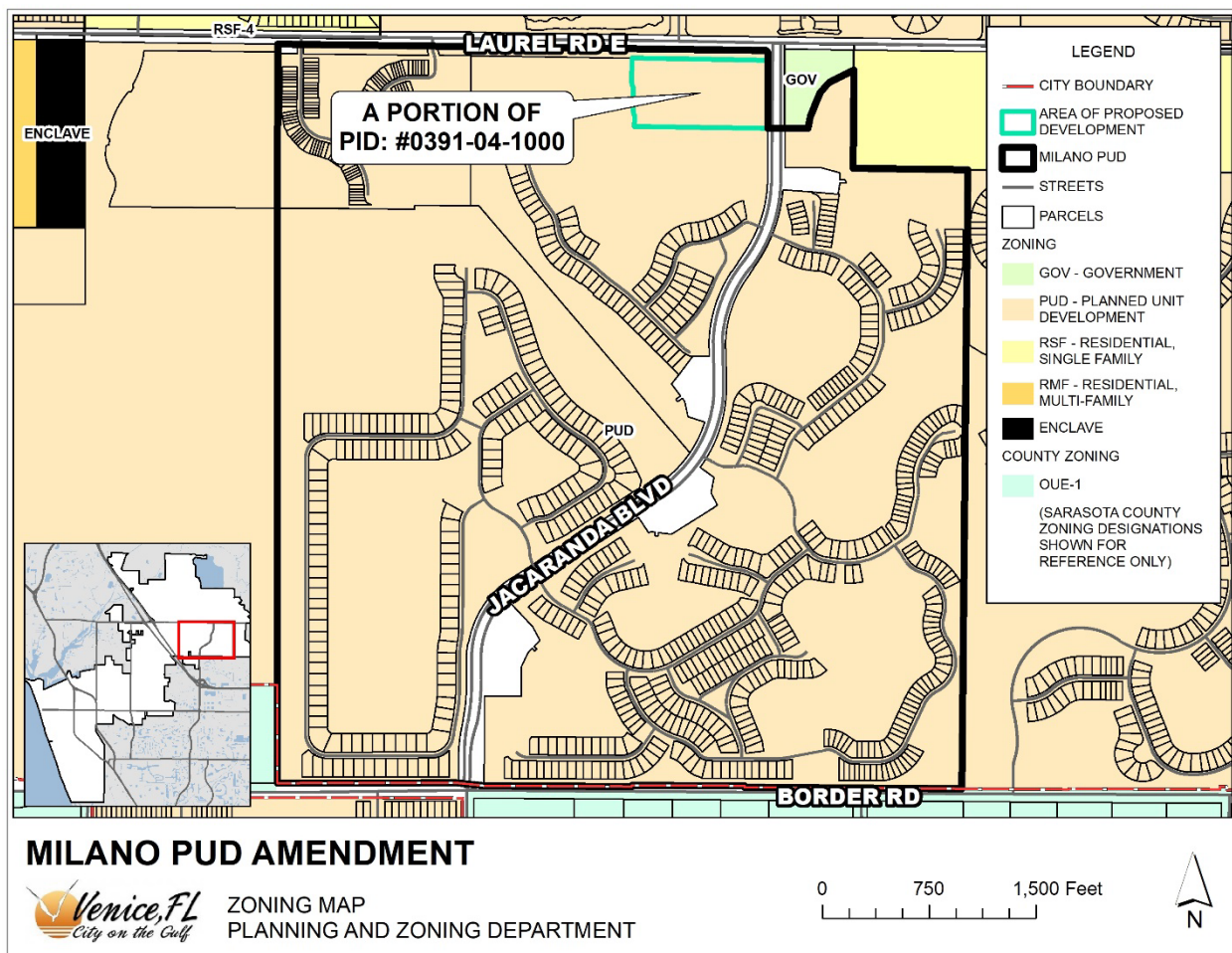

Any discrepancy between the legal description and the map shall resolve in favor of the map.

SECTION 4. All Ordinances or parts of Ordinances in conflict herewith shall be and the same are hereby repealed.

SECTION 5. If any part, section, subsection, or other portion of this ordinance or any application thereof to any person or circumstance is declared void, unconstitutional, or invalid for any reason, such part, section, subsection, or other portion, or the prescribed application thereof, shall be severable, and the remaining provisions of this ordinance, and all applications thereof not having been declared void, unconstitutional, or invalid, shall remain in full force and effect.

SECTION 6. Effective date. This ordinance shall take effect immediately upon its approval and adoption as provided by law.

PASSED BY THE CITY COUNCIL OF THE CITY OF VENICE, FLORIDA, THIS 13TH DAY OF JUNE 2023.

First Reading: May 23, 2023
Final Reading: June 13, 2023

Adoption: June 13, 2023

Nick Pachota, Mayor

Attest:

Kelly Michaels, MMC, City Clerk

I, Kelly Michaels, MMC, City Clerk of the City of Venice, Florida, a municipal corporation in Sarasota County, Florida, do hereby certify that the foregoing is a full and complete, true and correct copy of an Ordinance duly adopted by the City of Venice Council, a meeting thereof duly convened and held on the 13th day of June 2023 a quorum being present.

WITNESS my hand and the official seal of said City this 13th day of June 2023.

Kelly Michaels, MMC, City Clerk

Approved as to form:

Kelly Fernandez, City Attorney

Exhibit "A"

MILANO

PLANNED UNIT DEVELOPMENT (PUD)
BINDING MASTER PLAN AMENDMENT

~~April 4~~ November 16, 2022

ADOPTED BY ORDINANCE NO. 20223-
 , 20223

MILANO PUD AMENDMENT

PROJECT NARRATIVE

The Milano PUD is 528 ~~503.9~~+/- acre property located south of Laurel Road, north of Border Road, and bisected by the Jacaranda Boulevard Extension. The property is located within the Northeast Neighborhood of the Comprehensive Plan and has a Future Land Use Designation of Mixed Use Residential (MUR). The Milano PUD approved by Ordinance No. 2017-25 is a residential community consisting of detached single- family homes, paired villas, multi-family homes, amenity centers and open space. The density approved for the Milano PUD is up to 1,350 dwelling units.

The Milano PUD was amended by Ordinance No. 2020-40, which approved revisions to the PUD binding master plan which were all located within the approximately 36 acre development pod at the northwest corner of the Milano PUD, and were limited to the addition of one access point along Laurel Road and the restriction of the existing access point to egress only, the addition of project signage at the new access point, the addition of lot standards for townhomes, a modification of driveway standards for townhomes, the addition of an Amenity Area, the addition of alternative roadway sections to allow for on street parking, and minor modifications to conceptual stormwater pond configurations.

The Milano PUD was amended by Ordinance No 2022-23~~This proposed amendment is limited to the removal of 24.1 acres of open space along the western boundary of the Milano PUD, an area of open space which will be was added to the adjacent GCCF PUD and will remains open space within the GCCF PUD. Removal of the open space will reduced the Milano PUD acreage to 503.9 acres, the minimum 50% open space within the Milano PUD will be was maintained, or exceeded. No other changes are were proposed with this the amendment.~~

This amendment to the Milano PUD proposes to re-designate a 10.42 acre parcel at the southwest corner of the Jacaranda Boulevard and Laurel Road, within the Milano PUD, from Open Space to Commercial, to add access points for the Commercial parcel and establish development standards for the Commercial parcel. The proposed Commercial designated parcel will allow for the provision of limited retail and service uses to meet the needs of the residents of the PUD while reducing trip lengths and increasing multi-modal accessibility to such services for the residents. The PUD requirement for a minimum of 50% Open Space will continue to be maintained.

All internal roadways will be privately owned and maintained. The on-site storm water management system will be privately owned and maintained. Water and wastewater facilities will be dedicated to the City of Venice.

COMPLIANCE

The proposed amendment to the Milano PUD plan remains consistent with all applicable elements of the City's updated 2017 Comprehensive Plan. Specifically, the proposed amendment to the Milano PUD is consistent with *Land Use Element and Northeast Neighborhood Element Strategies LU 1.2.16, LU 1.2.17, and LU NE 1.1.1.A and C.*, with respect to density and open space, and with *Open Space Element Intents OS 1.1, OS1.2, OS 1.3, OS1.4, OS 1.5 and OS 1.6* with respect to open space uses, wetlands, native habitats and open space corridors, and with *Land Use Element Intent LU 4.1.*, with respect to transitional strategies related to compatibility, and development standards.

Finally, the proposed Milano PUD is in compliance with the City of Venice Land Development Code Sec. 86-130 requirements for Planned Unit Development (PUD) Districts as outlined in the below Land Use and Development Standards.

LAND USE AND DEVELOPMENT STANDARDS

The following identifies the proposed development standards for the Milano Planned Unit Development. In furtherance of the interpretation authority granted by the City of Venice Comprehensive Plan and Land Development Code, the Zoning Administrator shall have authority to administratively approve minor modifications of standards contained with the Milano Planned Unit Development, excluding standards related to density, building height, buffer widths, and the addition of permitted uses. Reasonable mitigation measures may be imposed by the Zoning Administrator to limit impacts from the requested adjustment of standards. Where the PUD master plan identifies areas for residential uses, the developer shall have the option to convert such residential use areas to open space uses.

Any standard not stated or otherwise addressed in the binding master plan is subject to Section 86-130, City of Venice PUD standards.

A. Land Uses

1) Permitted Principal Uses and Structures

- Residential single-family dwellings (detached)
- Residential single-family dwellings (attached)
- Townhomes
- Multi-family dwellings
- Private club, community centers and civic and social organization facilities
- Recreational areas
- Open Space
- Convenience Stores
- Grocery Stores
- Pharmacies
- Produce markets
- Bakeries
- Florists
- Gift Shops

- Liquor stores
- Hair and beauty care and other similar services
- Pet grooming
- Health spas
- Clothing repair and alteration
- Dry cleaning/laundry services
- Studios for instruction in dance, music, yoga, cheer/gymnastics and fitness
- Professional and business offices, medical and dental clinics
- Banks and financial institutions
- Restaurants

2) Permitted accessory uses and structures

- Are customarily accessory and clearly incidental and subordinate to permitted or permissible uses and structures.
- Are located on the same lot as the permitted or permissible use or structure or on a contiguous lot in the same ownership.
- Do not involve operations or structures not in keeping with the character of the district.
- Do not involve the conduct of business on residential premises, provided that accessory home occupations shall be allowed as accessory to residential uses.

B. Density/ Intensity

1) Residential- Up to 1,350 residential units

2) Commercial- ~~None~~ Maximum 10.42 acres

- Maximum 0.5 FAR

- No single use retail in excess of 65,000 square feet

3) Open Space- Minimum 50%

C. Maximum Height of Structures- 3 stories up to 42' including parking.

D. LOT DETAIL

1) Single-Family Detached

- Minimum Lot Size: 4,500 square feet
- Maximum Lot Coverage: None, except as required to meet other requirements set out in this section
- Lot Width: 40 feet
- Front Yard: 20 feet, or 15 feet when building has side entry garage
- Side Yard: 5 feet
- Rear Yard: 10 feet
- Accessory structures/appurtenant structures including, but not limited to pool cages, may be located within five feet of the rear lot line

2) Single-Family Attached (Paired Villas)

- Minimum Lot Size: 4,140 square feet
- Maximum Lot Coverage: None, except as required to meet other requirements set out in this section
- Lot Width: 36 feet
- Front Yard: 20 feet
- Side Yard: 5 feet
- Rear Yard: 10 feet
- Accessory structures/appurtenant structures including, but not limited to pool cages, may be located within five feet of the rear lot line

3) Townhomes

- Minimum Lot Size: 1,800 square feet
- Maximum Lot Coverage: None, except as required to meet other requirements set out in this section
- Lot Width: 18 feet
- Front Yard: 20 feet
- Side Yard: none
- Rear Yard: 10 feet
- Accessory structures/appurtenant structures including, but not limited to pool cages, may be located within five feet of the rear lot line

4) Multi-Family

- Minimum Lot Size: 10,400 square feet
- Maximum Lot Coverage: None, except as required to meet other requirements as set out in this section
- Lot Width: 130 feet
- Front Yard: 20 feet
- Side Yard: 5 feet
- Rear Yard: 10 feet
- Accessory structures/appurtenant structures including, but not limited to pool cages, may be located within five feet of the rear lot line

5) Commercial

- Minimum Lot Size: None, except as required to meet other requirements as set out in this section
- Maximum Lot Coverage: None, except as required to meet other requirements as set out in this section
- Lot Width: None, except as required to meet other requirements as set out in this section
- Front Yard: 10 Feet
- Side Yard: None
- Rear Yard: 10 Feet

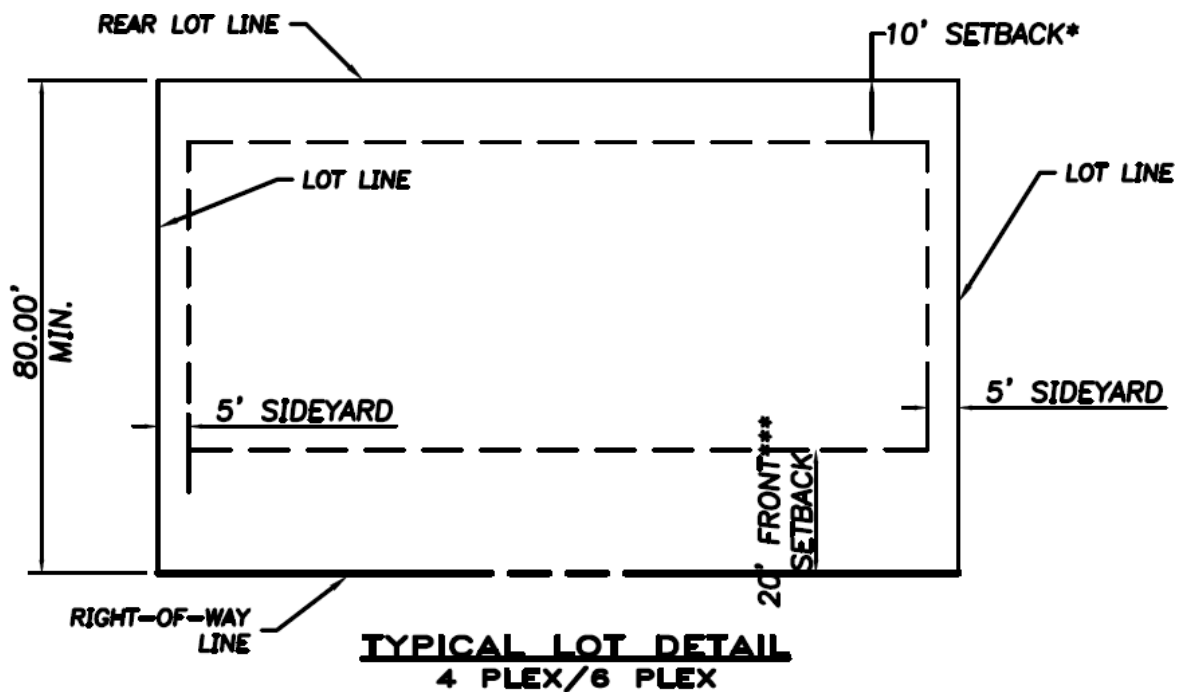
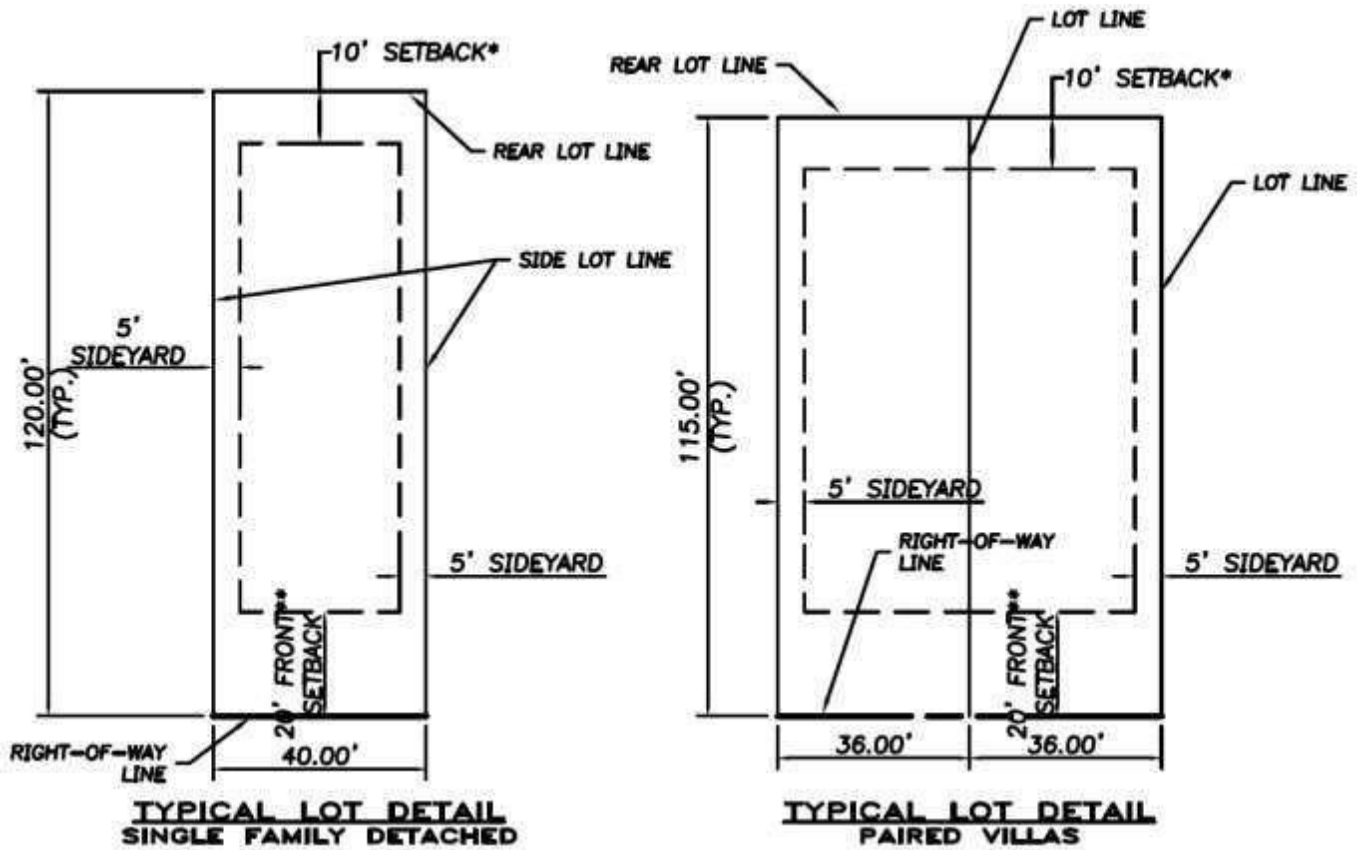

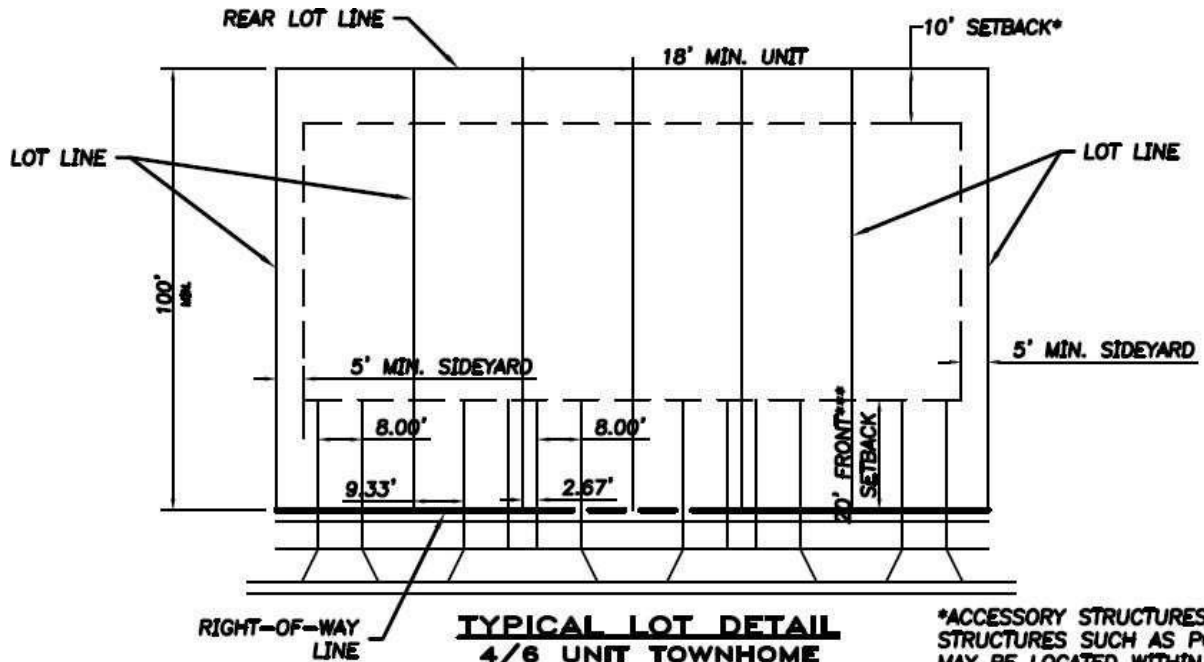

*ACCESSORY STRUCTURES/APPURTENANT STRUCTURES SUCH AS POOL CAGES, MAY BE LOCATED WITHIN FIVE FEET OF THE REAR LOT LINE.

**FRONT SETBACK MAY BE REDUCED TO 15' WHEN THE BUILDING HAS A SIDE ENTRY GARAGE

***SETBACKS ARE MINIMUMS AND MAY BE EXCEEDED WHERE NECESSARY

E. BUFFERS/ LANDSCAPING

RESIDENTIAL

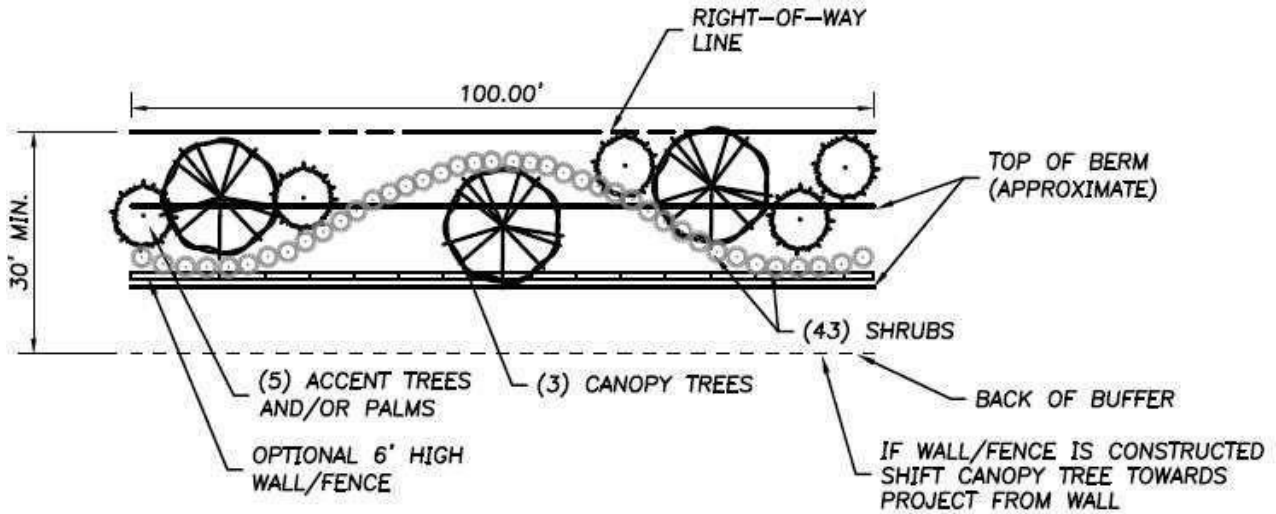

JACARANDA BOULEVARD TYPICAL BUFFER

NOTES:

PLANT MATERIAL AND WALL LOCATION DEPENDS ON EXISTING SARASOTA COUNTY UTILITIES LOCATIONS BERM CONSTRUCTION RESTRICTIONS PER SARASOTA COUNTY UTILITY DEPARTMENT.

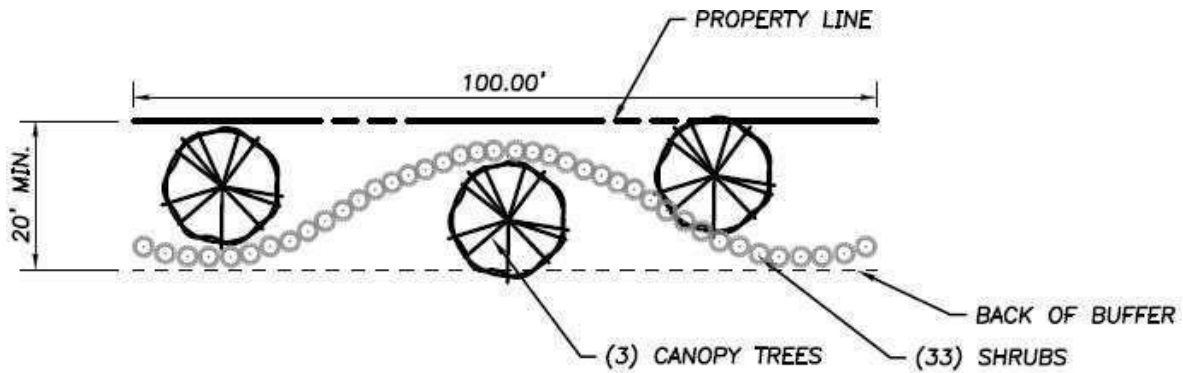

EAST PROPERTY LINE TYPICAL BUFFER

NOTES:

1. EXISTING VEGETATION TO REMAIN WHERE FEASIBLE TO SATISFY BUFFER PLANTING REQUIREMENTS
2. TYPICAL BUFFER REQUIREMENTS WILL NOT APPLY WHERE EXISTING WETLANDS ARE TO REMAIN.

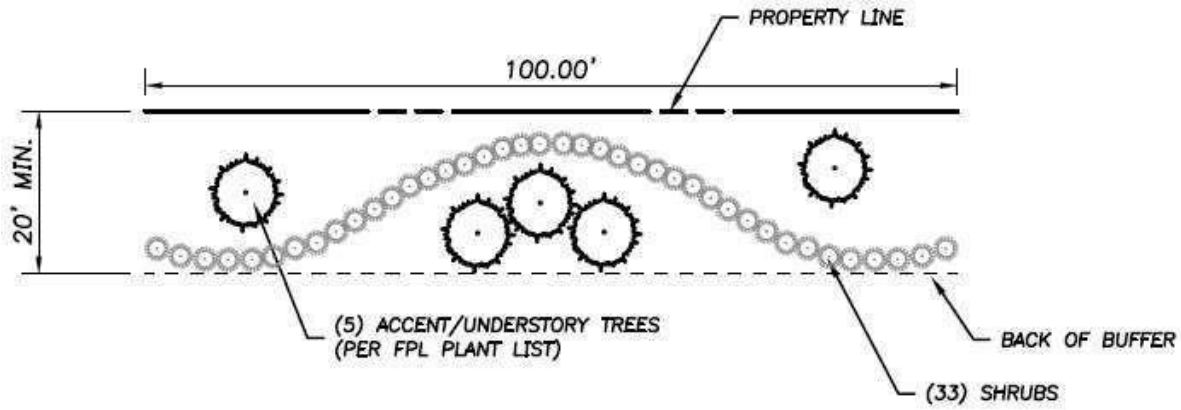

WEST PROPERTY LINE BUFFER (TYPE A)(FPL EASEMENT)

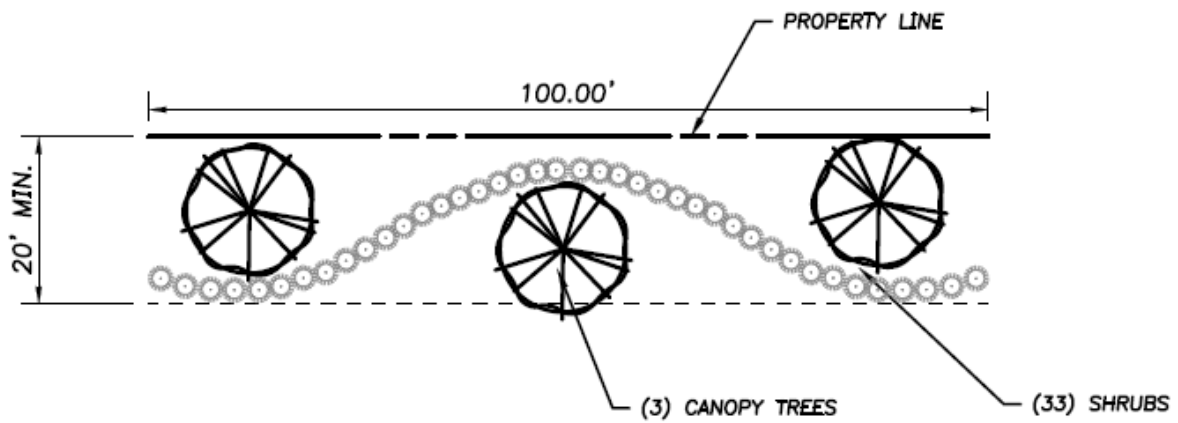

WEST PROPERTY LINE BUFFER (TYPE B)(NO FPL EASEMENT)

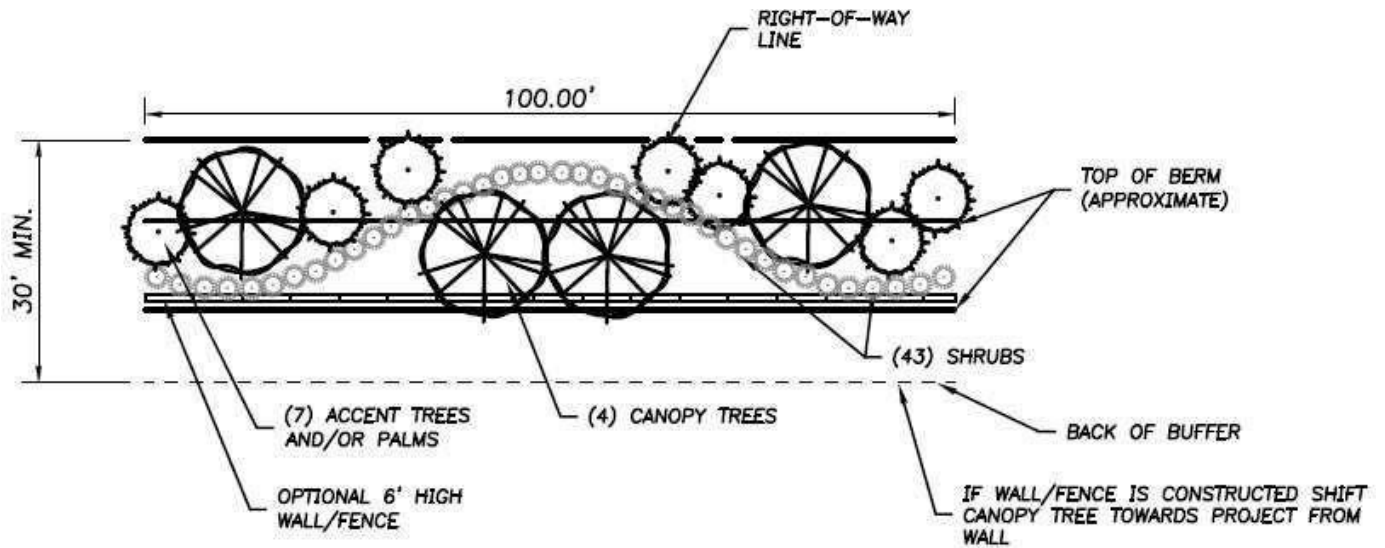

**LAUREL ROAD AND BORDER ROAD TYPICAL BUFFER (60% OPACITY)
(TYPE C)– WITH FPL CONFLICT**

NOTES:

1. EXISTING VEGETATION TO REMAIN WHERE FEASIBLE TO SATISFY BUFFER PLANTING REQUIREMENTS
2. TYPICAL BUFFER REQUIREMENTS WILL NOT APPLY WHERE EXISTING WETLANDS ARE TO REMAIN.
3. WHERE OVERHEAD UTILITY POLE LOCATIONS RESTRICT VERTICAL VEGETATION HEIGHTS, ACCENT TREES AS DEFINED BY SARASOTA COUNTY SHALL BE USED IN LIEU OF A CANOPY TREE.

COMMERCIAL

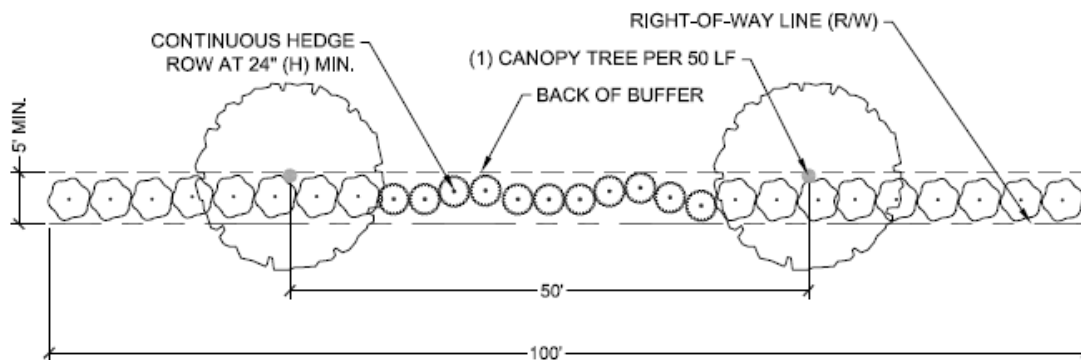

Laurel Road and Jacaranda Boulevard Typical Buffer

NOTES:

1. PLANT MATERIAL SPECIES AND LOCATION DEPENDS ON EXISTING UTILITY LOCATIONS.
2. AN OPAQUE WALL CAN BE USED IN LIEU OF A CONTINUOUS HEDGE. IF A WALL IS TO BE UTILIZED ONE SHRUB/VINE PER 10 LINEAR FEET SHALL BE PLANTED. THESE SHRUBS/VINES SHALL NOT BE PLANTED EVERY 10 FEET.
3. SHRUBS/VINES SHALL BE PLANTED STREET SIDE UNLESS THEY ARE OF SUFFICIENT HEIGHT AT THE TIME OF PLANTING.
4. THE REMAINDER OF THE BARRIER SHALL BE LANDSCAPED WITH GRASS, GROUND COVER OR OTHER LANDSCAPE TREATMENT.

F. Roadway Design

1) The Milano PUD proposes an alternative neighborhood roadway design with the following standards (see typical roadway section below):

- Right-of-Way: 43 feet
- Travel Lanes: 10 feet
- Sidewalk: 5 feet, one side of street only
- 2 foot curb
- One (1) tree per lot which may be placed within or adjacent to the ROW, minimum 3" caliper at installation

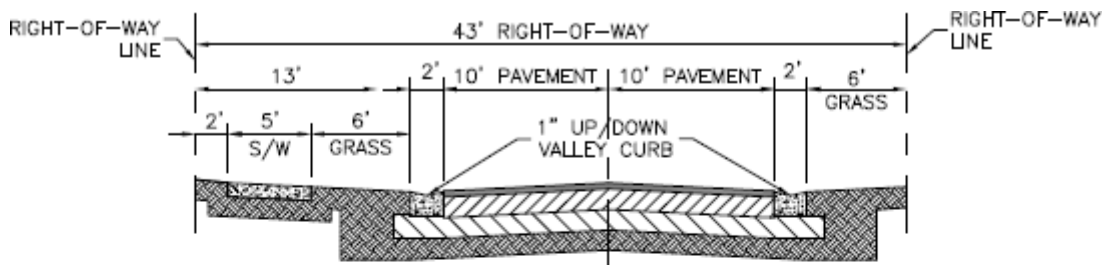

TYPICAL NEIGHBORHOOD ROADWAY SECTION

NOTES:

1. ALL PRIVATE LOCAL STREET RIGHT OF WAYS TO BE INGRESS/EGRESS, UTILITY AND DRAINAGE EASEMENTS, AND PUBLIC UTILITY EASEMENTS.
 2. NO UTILITY SERVICES IN SIDEWALK.
 3. THERE SHALL BE NO ON-STREET PARKING PERMITTED.
- 2) Pursuant to Sec. 86-233(3) City Council Approval of dead-end streets (cul-de-sacs) up to 1,200 feet in length is requested.
- 3) Pursuant to City of Venice Comprehensive Plan, Housing and Neighborhood Development Policy 2.6, City Council approval of limited access gates for neighborhood roads is requested.
- 4) The Milano PUD proposes the additional alternative roadway design standards for the 36 acre development pod at the northwest corner of the Milano PUD.

ROADWAY SECTIONS

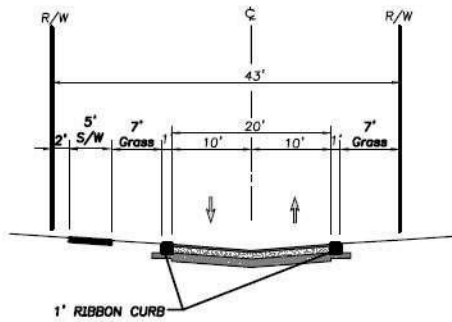

INVERTED CROWN 43' RIGHT-OF-WAY SECTION
20' PAVEMENT
- NO SCALE -

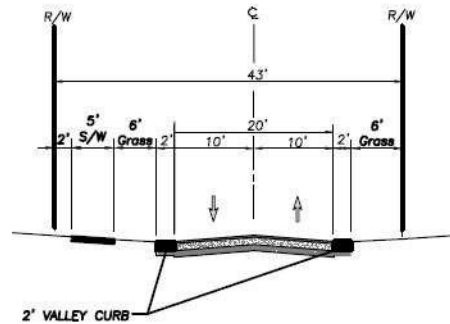

TYPICAL NEIGHBORHOOD ROADWAY SECTION
20' PAVEMENT
- NO SCALE -

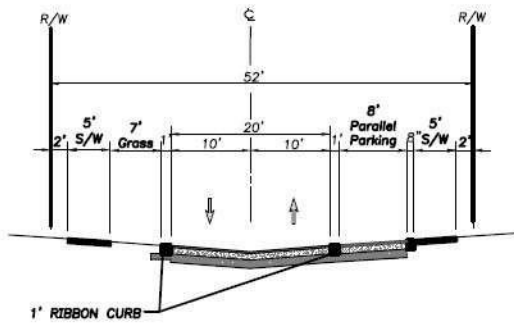

INVERTED CROWN 52' RIGHT-OF-WAY SECTION
PARALLEL PARKING
20' PAVEMENT
- NO SCALE -

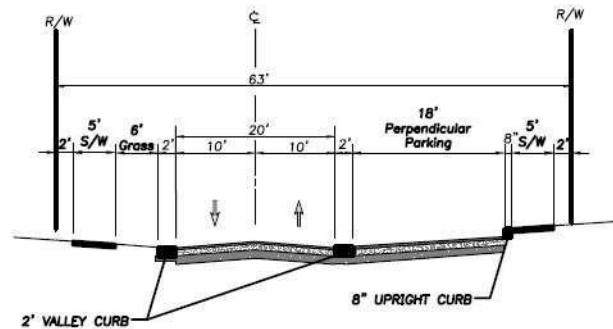

CROWN 63' RIGHT-OF-WAY SECTION
PERPENDICULAR PARKING
20' PAVEMENT
- NO SCALE -

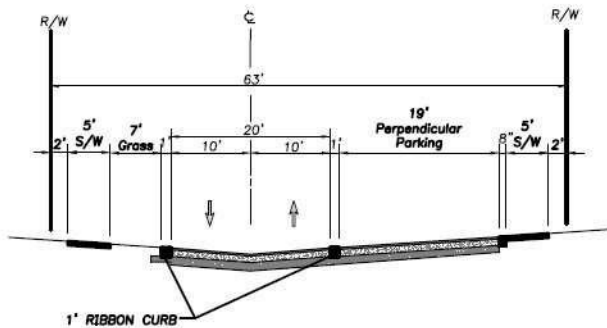

INVERTED CROWN 63' RIGHT-OF-WAY SECTION
PERPENDICULAR PARKING
20' PAVEMENT
- NO SCALE -

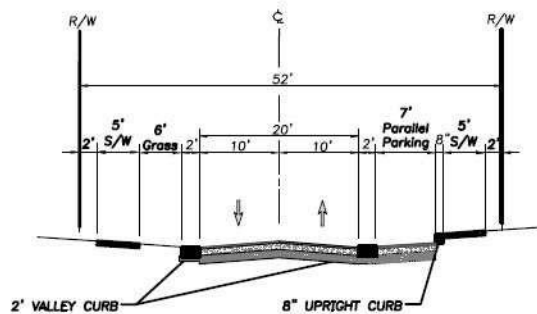

CROWN 52' RIGHT-OF-WAY SECTION
PARALLEL PARKING
20' PAVEMENT
- NO SCALE -

NOTES:

1. ALL PRIVATE LOCAL STREET RIGHT OF WAY TO BE INGRESS/EGRESS, UTILITY AND DRAINAGE EASEMENTS, AND PUBLIC UTILITY EASEMENTS.
2. NO UTILITY SERVICES IN SIDEWALK.

G. SIGNAGE: No signs are permitted in the Milano PUD except:

RESIDENTIAL

- 1) One non-illuminated temporary construction project ground sign per street frontage, not exceeding 32 square feet in area, such sign not to be erected more than 60 days prior to the time actual construction begins, and to be removed upon completion of actual construction. If construction is not begun within 60 days or if construction is not continuously and actively prosecuted to completion, the sign shall be removed.
- 2) One community identification, monument-style ground sign, not to exceed nine (9) feet in height and twenty (20) feet in width, on each side, or in the median and one side, of each vehicular access point off Laurel Road and Jacaranda Boulevard, including access points at the intersections of Laurel Road and Jacaranda Boulevard, and Border Road and Jacaranda Boulevard.
- 3) One wall or monument-style ground sign, not over eight square feet in area, to identify a private club.

COMMERCIAL

- 1) Monument Ground Sign - one per vehicular access point off Laurel Road and Jacaranda Boulevard, maximum sign face 100 square feet, maximum area of structure including sign face 250 square feet, maximum height 15 feet.
- 2) Building Sign - Single-tenant building 1.5 sq. ft. per linear foot of building frontage OR 150 sq. ft. total, whichever is less.
- 3) Multi-tenant building 1.5 sq. ft. per linear foot of tenant space with public entrance.

- H. Architectural Design Standards: Pursuant to City of Venice Comprehensive Plan, Future Land Use and Design Element, Policy 16.18.G.1, the Milano PUD will apply Northern Italian Architectural Design.

Building. Home. Life.

TYPICAL HOUSING STYLES

NEAL COMMUNITIES

PROPOSED MILANO PUD MODIFICATION TO STANDARDS

- 1) A modification to the requirements of Sec. 86-130 (q), concerning the requirement that no structure shall be located closer to any perimeter property line than two times the height of such structure, is requested. The proposed modification is to reduce the required setback from perimeter property lines to one times the building height.

The proposed modification request is justified based upon the low intensity of the development plan, the extensive perimeter buffers and the significant amount of open space otherwise provided.

- 2) A modification to the requirements of Sec 86-232(5) concerning the roadway design standards is proposed and an alternative neighborhood roadway design is proposed. The proposed modification reduces right-of way width from 52' to 43', allows for sidewalks on one side of the neighborhood roadway only, and eliminates bike lanes for the neighborhood roadways.

The proposed modification request is justified based upon the protection of wetlands and their buffers afforded by the modification, the low intensity of the development plan, and the circulation plan which demonstrate sidewalks on one side of the street will provide excellent pedestrian connectivity from each of the development pods to the amenity center and also to the sidewalk and multi-use trail along Jacaranda Boulevard.

- 3) A modification to Sec. 86-130 (h) is requested concerning building height. The proposed modification is to replace the Land Development Code standard of 35' over 10' of parking with the Comprehensive Plan standard of 3 stories up to 42' including parking.

The proposed modification, at the direction of City staff, is necessary to address an inconsistency between the City's Land Development Code and its Comprehensive Plan.

- 4) A modification to Sec. 86-423(b) is requested concerning driveway standards for Townhomes. The proposed modification is to substitute the driveway dimension as depicted on the Typical Lot Detail for Townhomes (Page 6), and to reduce the required minimum distance from the edge of pavement of two intersecting streets from 40 feet to 30 feet.

The proposed modification is justified based upon the width of Townhome lots, and the limited number of driveways which will be located in proximity to the intersection of two streets, and the number of lots that would not meet the 40 foot standard (one lot).

- 5) A modification to the requirements of Sec. 86-437. - Landscaping adjacent to property lines is requested to eliminate the requirement for a landscape buffer along the southern boundary of the commercial parcel.

The proposed modification is justified due the location of the 330 foot wide FPL easement located along the entire southern boundary and the significant amount of remaining vegetation providing a natural buffer within and to the south of the FPL easement between the nearest adjacent residences in excess of 500 feet from the southern boundary.

PLANNED UNIT DEVELOPMENT PLANS FOR

MILANO

PART OF SECTION 35, TOWNSHIP 38 SOUTH, RANGE 19 EAST
CITY OF VENICE
SARASOTA COUNTY, FL

A DEVELOPMENT BY
NEAL COMMUNITIES OF SOUTHWEST FLORIDA, LLC
5800 LAKEWOOD RANCH BOULEVARD
SARASOTA, FL 34240
(941) 328-1111

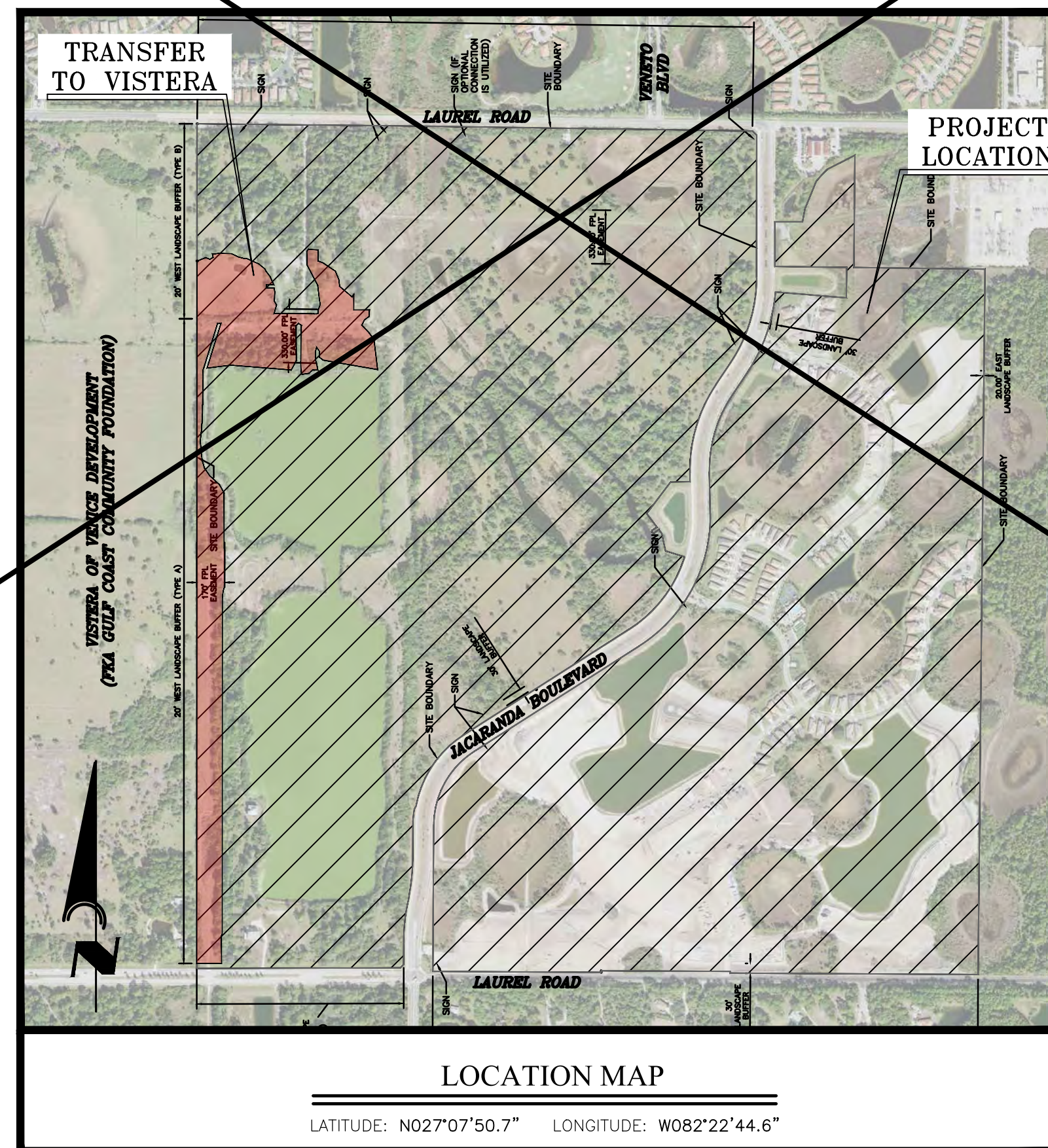

INDEX TO SHEETS

SHEET NO.	DESCRIPTION
1	COVER SHEET
2	MASTER SITE PLAN
3	CIRCULATION PLAN

© AM Engineering 2022. Saved: 7/12/2022 3:39:52 PM. E:\Projects\2121\2022-34921.dwg | Plotter: 2/12/2022 3:40:21 PM | L:\Bosch\N24\001\Bosch\N24\001.dwg | Micro Plot Modification COVER

REV. No.	REV. DATE	REVISION DESCRIPTION	BY	REV. No.	REV. DATE	REVISION DESCRIPTION	BY

CALL BEFORE YOU DIG!
"SUNSHINE STATE ONE-CALL CENTER"
1-800-432-4770
THE CONTRACTOR SHALL NOTIFY "SUNSHINE STATE ONE-CALL CENTER" AND ALL OTHER UTILITIES FOR LOCATION OF EXISTING FACILITIES PRIOR TO BEGINNING CONSTRUCTION.

ISSUE DATE: **JANUARY 27, 2022** CHECKED BY: **BRC**

ISSUE DESCRIPTION: **PUD MODIFICATION**

AM ENGINEERING, LLC.

Civil Engineering | Land Surveying

8340 Consumer Court Sarasota, FL 34240
Phone: (941) 377-9178 | www.amengll.com
CA #33105 | LB #4334

CLIENT:	NEAL COMMUNITIES OF SOUTHWEST FLORIDA, LLC
PROJECT:	MILANO
TITLE:	COVER SHEET

HORIZONTAL SCALE:	1" = 300'
VERTICAL SCALE:	N/A
VERTICAL DATUM:	N/A
PROJECT NUMBER:	NEAL0016PUD
SHEET NUMBER:	1

PROJECT ENGINEER:

BOBBI R. CLAYBROOKE, PE
DATE: _____
FLORIDA P.E. No. 90804

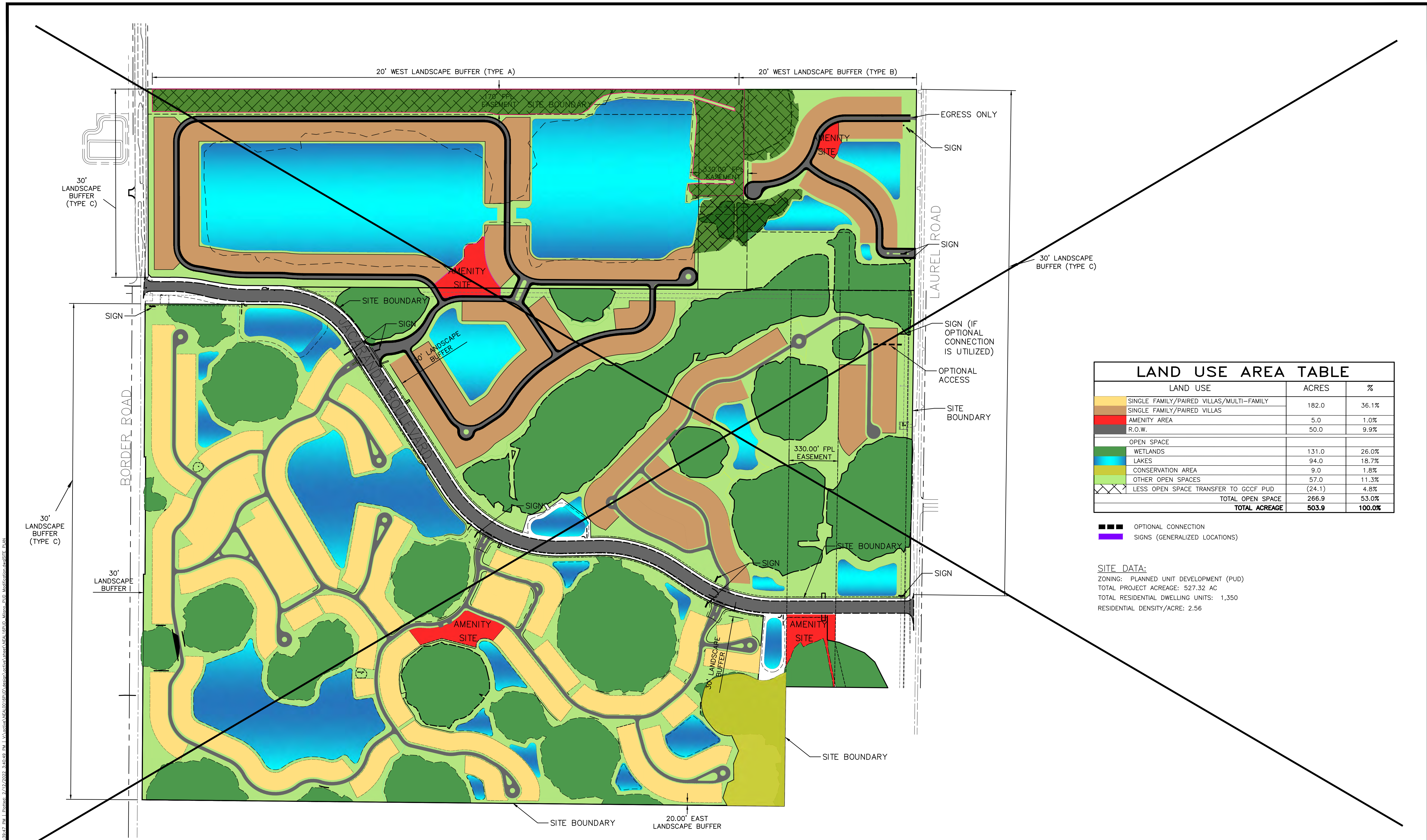

LAND USE AREA TABLE		
LAND USE	ACRES	%
SINGLE FAMILY/PAIRED VILLAS/MULTI-FAMILY	182.0	36.1%
SINGLE FAMILY/PAIRED VILLAS	5.0	1.0%
AMENITY AREA	50.0	9.9%
R.O.W.		
OPEN SPACE		
WETLANDS	131.0	26.0%
LAKES	94.0	18.7%
CONSERVATION AREA	9.0	1.8%
OTHER OPEN SPACES	57.0	11.3%
LESS OPEN SPACE TRANSFER TO GCCF PUD	(24.1)	4.8%
TOTAL OPEN SPACE	266.9	53.0%
TOTAL ACREAGE	503.9	100.0%

- OPTIONAL CONNECTION
- SIGNS (GENERALIZED LOCATIONS)

SITE DATA:
 ZONING: PLANNED UNIT DEVELOPMENT (PUD)
 TOTAL PROJECT ACREAGE: 527.32 AC
 TOTAL RESIDENTIAL DWELLING UNITS: 1,350
 RESIDENTIAL DENSITY/ACRE: 2.56

REV. No.	REV. DATE	REVISION DESCRIPTION	BY	REV. No.	REV. DATE	REVISION DESCRIPTION	BY

CALL BEFORE YOU DIG!
 "SUNSHINE STATE ONE-CALL CENTER"
 1-800-432-4770
 THE CONTRACTOR SHALL NOTIFY "SUNSHINE STATE ONE-CALL CENTER" AND ALL OTHER UTILITIES FOR LOCATION OF EXISTING FACILITIES PRIOR TO BEGINNING CONSTRUCTION.

ISSUE DATE: **JANUARY 27, 2022**

ISSUE DESCRIPTION: **PUD MODIFICATION**

Civil Engineering | Land Surveying

AM ENGINEERING, LLC.

8340 Consumer Court Sarasota, FL 34240
 Phone: (941) 377-9178 | www.amengll.com
 CA #33105 | LB #4334

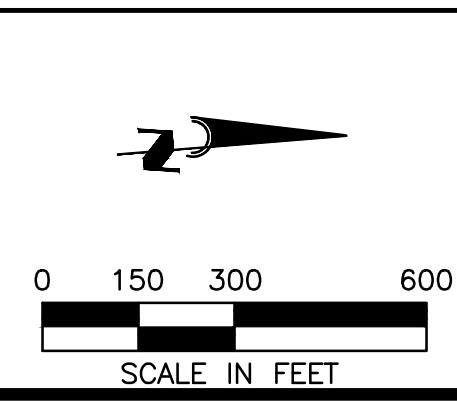

CLIENT: **NEAL COMMUNITIES OF SOUTHWEST FLORIDA, LLC**

PROJECT: **MILANO PUD**

TITLE: **MASTER SITE PLAN**

HORIZONTAL SCALE:	1" = 300'
VERTICAL SCALE:	N/A
PROJECT NUMBER:	NEAL0016PUD
SHEET NUMBER:	2

PROJECT ENGINEER: **BOBBI R. CLAYBROOKE, PE**

DATE: _____

FLORIDA P.E. No. 90804

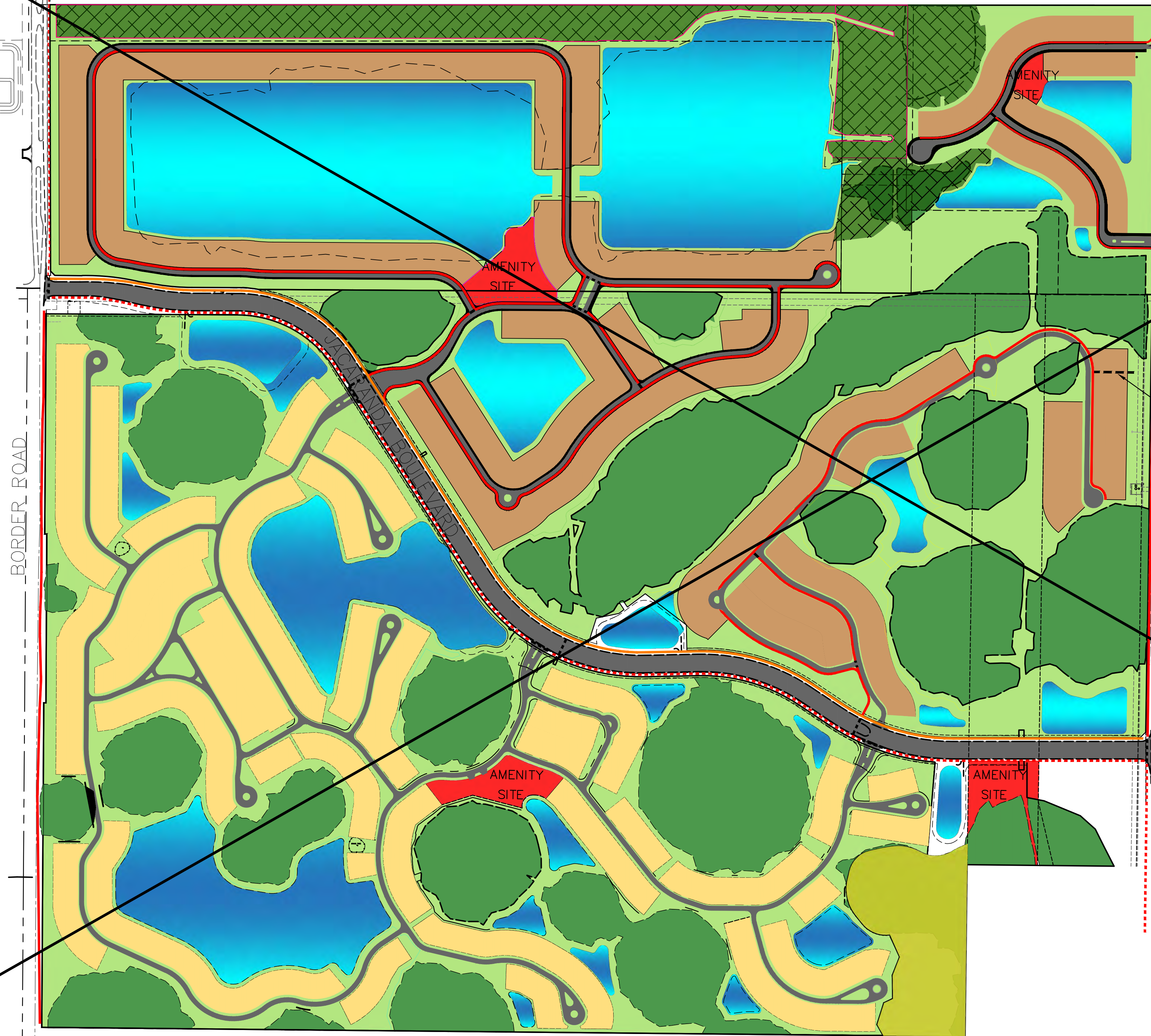

- LEGEND:**
- SINGLE FAMILY/PAIRED VILLAS/MULTI-FAMILY
 - SINGLE FAMILY/PAIRED VILLAS
 - AMENITY AREA
 - R.O.W.
 - WETLANDS
 - LAKES
 - CONSERVATION AREA
 - OTHER OPEN SPACES
 - OPEN SPACE TRANSFER TO GCCF PUD
 - OPTIONAL CONNECTION
 - EXISTING 5' SIDEWALK
 - PROPOSED 5' SIDEWALK
 - CROSSWALK
 - EXISTING 12' MULTI-USE RECREATION TRAIL

EGRESS ONLY

AUREL ROAD

OPTIONAL ACCESS

BORDER ROAD

JUNCALINDA BOULEVARD

AMENITY SITE

AMENITY SITE

AMENITY SITE

AMENITY SITE

© AM Engineering 2022. Sheet: 2/12/2022, 3:52:03 PM. I:\Projects\2022\2022-3-418-01 - Erietta - 2/12/2022 - 3:52:03 PM. I:\Projects\2022\2022-3-418-01\Drawings\Sheet\2022-3-418-01-PUD Modification.dwg. P:\AN

REV. No.	REV. DATE	REVISION DESCRIPTION	BY	REV. No.	REV. DATE	REVISION DESCRIPTION	BY

CALL BEFORE YOU DIG!
 "SUNSHINE STATE ONE-CALL CENTER"
 1-800-432-4770
 THE CONTRACTOR SHALL NOTIFY "SUNSHINE STATE ONE-CALL CENTER" AND ALL OTHER UTILITIES FOR LOCATION OF EXISTING FACILITIES PRIOR TO BEGINNING CONSTRUCTION.

ISSUE DATE: **JANUARY 27, 2022**

ISSUE DESCRIPTION: **PUD MODIFICATION**

ISSUED BY: **BRC**

Civil Engineering | Land Surveying



AM ENGINEERING, LLC.

8340 Consumer Court Sarasota, FL 34240
 Phone: (941) 377-9178 | www.amengll.com
 CA #33105 | LB #4334

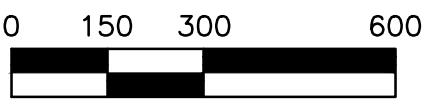
SCALE IN FEET

CLIENT:	NEAL COMMUNITIES OF SW FLORIDA, LLC
PROJECT:	MILANO PUD
TITLE:	CIRCULATION PLAN

HORIZONTAL SCALE:	1" = 300'
VERTICAL SCALE:	N/A
PROJECT DATUM:	N/A
PROJECT NUMBER:	NEAL0016PUD
SHEET NUMBER:	3

PROJECT ENGINEER:

BOBBI R. CLAYBROOKE, PE
 DATE: _____
 FLORIDA P.E. No. 90804

PLANNED UNIT DEVELOPMENT PLANS FOR

MILANO

PART OF SECTION 35, TOWNSHIP 38 SOUTH, RANGE 19 EAST
CITY OF VENICE
SARASOTA COUNTY, FL

A DEVELOPMENT BY
NEAL COMMUNITIES OF SOUTHWEST FLORIDA, LLC
5800 LAKEWOOD RANCH BOULEVARD
SARASOTA, FL 34240
(941) 328-1111

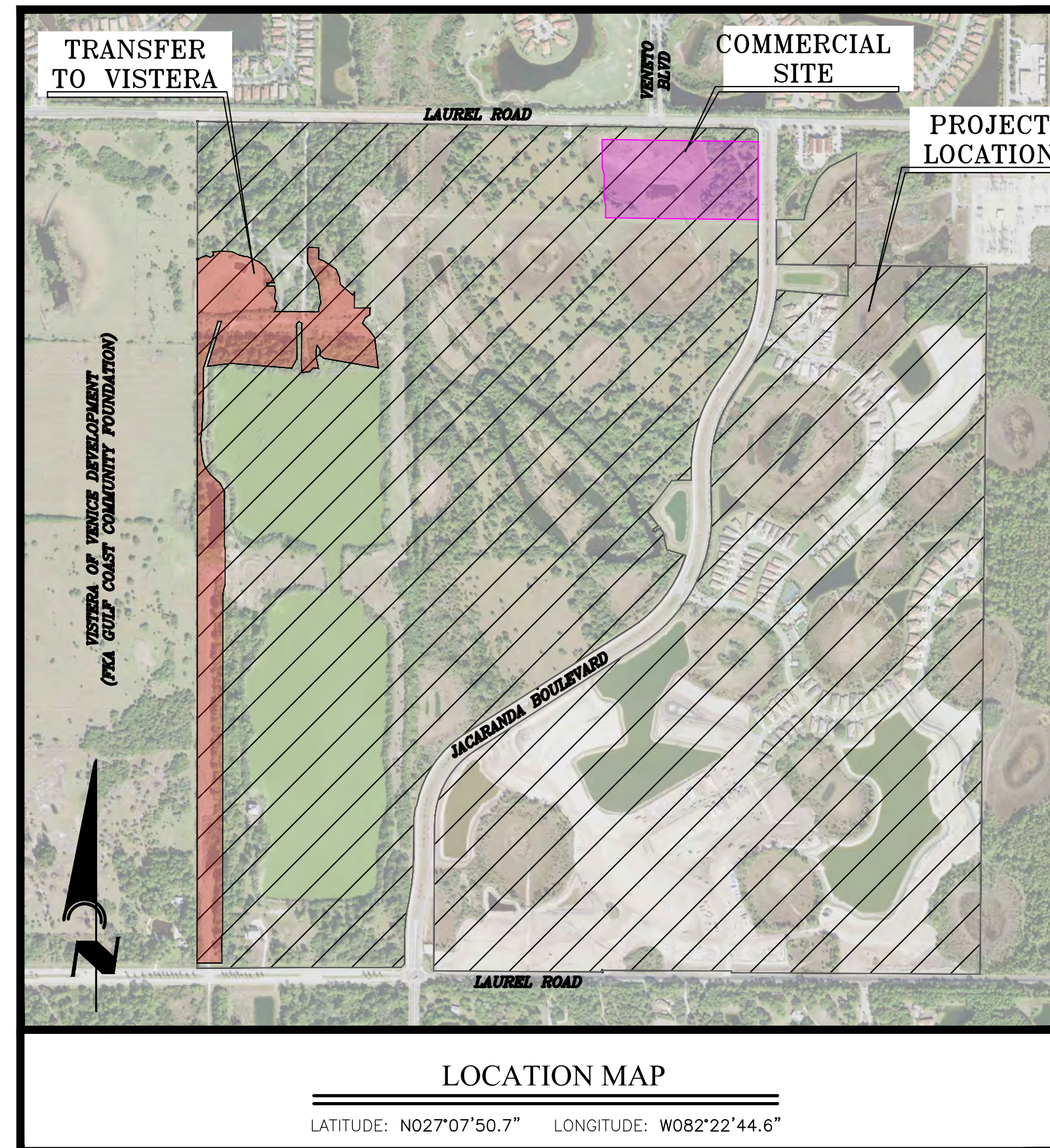

INDEX TO SHEETS

SHEET NO.	DESCRIPTION
1	COVER SHEET
2	MASTER SITE PLAN
3	CIRCULATION PLAN

© AM Engineering 2022. Saved: 11/22/2022 3:15:44 PM. I:\Projects\2022\11\22\2022_31544_Plan_1\Aerial\NEAL0016PUD\Design\LocationMap\MILANO_PUD_Modification_Rev_for_CoverSheet.dwg

REV. No.	REV. DATE	REVISION DESCRIPTION	BY
3	11/14/22	RESPONSE TO CITY COMMENTS	BRC
2	06/06/22	MODIFY FOR COMMERCIAL SITE	BRC
1	03/30/22	RESPONSE TO CITY COMMENTS	BRC

CALL BEFORE YOU DIG!
"SUNSHINE STATE ONE-CALL CENTER"
1-800-432-4770
THE CONTRACTOR SHALL NOTIFY "SUNSHINE STATE ONE-CALL CENTER" AND ALL OTHER UTILITIES FOR LOCATION OF EXISTING FACILITIES PRIOR TO BEGINNING CONSTRUCTION.

ISSUE DATE: **JANUARY 27, 2022** CHECKED BY: **BRC**

ISSUE DESCRIPTION: **PUD MODIFICATION**

AM ENGINEERING, LLC.
Civil Engineering | Land Surveying
8340 Consumer Court Sarasota, FL 34240
Phone: (941) 377-9178 | www.amengfl.com
CA #33105 | LB #4334

CLIENT:	NEAL COMMUNITIES OF SOUTHWEST FLORIDA, LLC
PROJECT:	MILANO
TITLE:	COVER SHEET

HORIZONTAL SCALE:	1" = 300'
VERTICAL SCALE:	N/A
VERTICAL DATUM:	N/A
PROJECT NUMBER:	NEAL0016PUD
SHEET NUMBER:	1

Bobbi Claybrooke
Digitally signed by Bobbi Claybrooke
DN: c=US, st=Florida, l=Sarasota, o=AM Engineering, LLC, cn=Bobbi Claybrooke,
email=bclaybrooke@amengfl.com
Date: 2022.11.16 16:27:27 -05'00'

BOBBI R. CLAYBROOKE, PE
DATE: 11/16/22
FLORIDA P.E. No. 90804

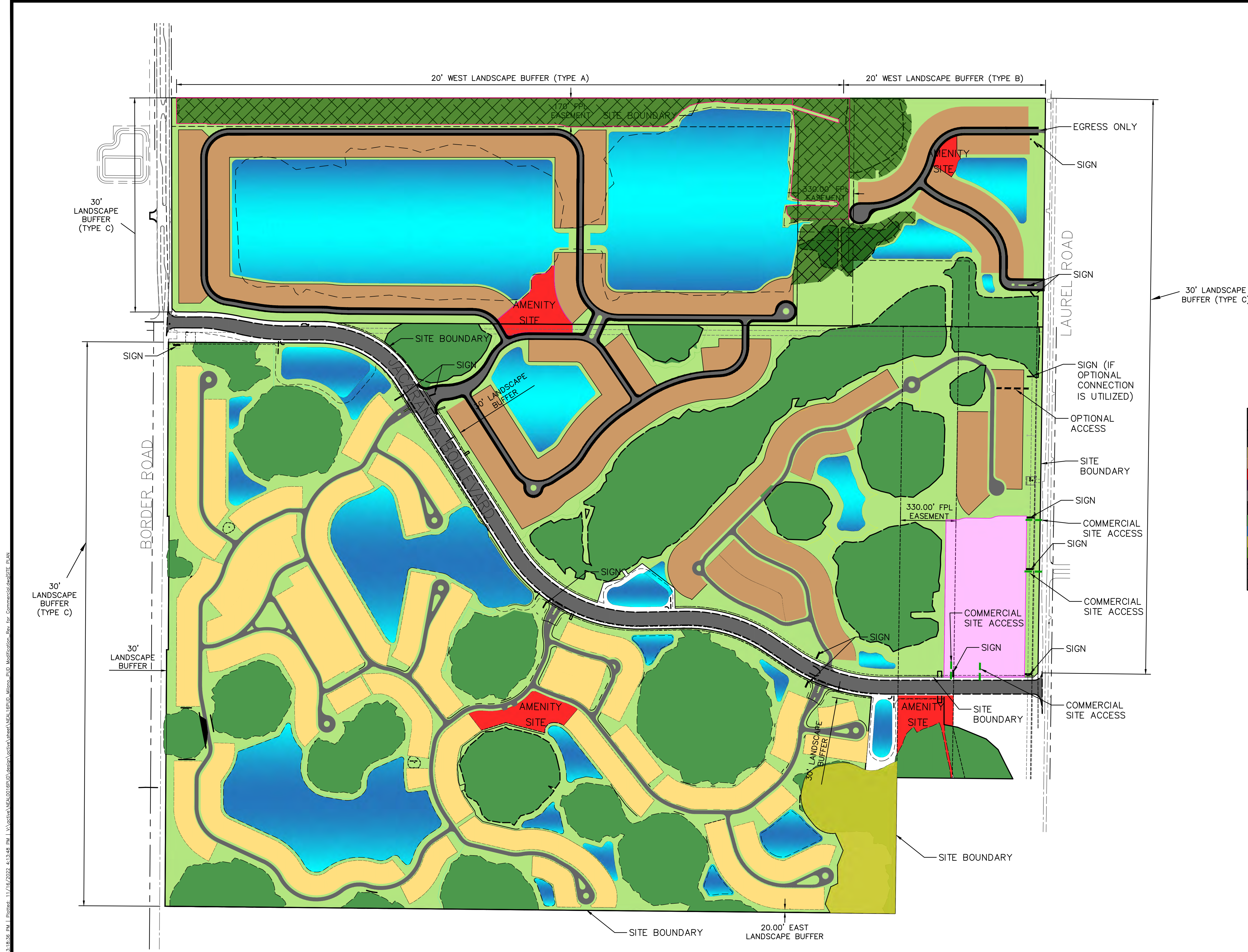

LAND USE AREA TABLE

LAND USE	ACRES	%
SINGLE FAMILY/PAIRED VILLAS/MULTI-FAMILY	182.0	36.1%
SINGLE FAMILY/PAIRED VILLAS		
AMENITY AREA	5.0	1.0%
COMMERCIAL SITE	10.4	2.1%
R.O.W.	50.0	9.9%
OPEN SPACE		
WETLANDS	122.2	24.2%
LAKES	92.2	18.3%
CONSERVATION AREA	9.0	1.8%
OTHER OPEN SPACES	57.2	11.4%
LESS OPEN SPACE TRANSFER TO GCCF PUD	(24.1)	4.8%
TOTAL OPEN SPACE	256.5	50.9%
TOTAL ACREAGE	503.9	100.0%

OPTIONAL CONNECTION
SIGNS (GENERALIZED LOCATIONS)
COMMERCIAL ACCESS

SITE DATA:
 ZONING: PLANNED UNIT DEVELOPMENT (PUD)
 TOTAL PROJECT ACREAGE: 503.9 AC
 TOTAL RESIDENTIAL DWELLING UNITS: 1,350
 RESIDENTIAL DENSITY/ACRE: 2.68

REV. No.	REV. DATE	REVISION DESCRIPTION	BY	REV. No.	REV. DATE	REVISION DESCRIPTION	BY
3	11/14/22	RESPONSE TO CITY COMMENTS	BRC				
2	06/06/22	MODIFY FOR COMMERCIAL SITE	BRC				
1	03/30/22	RESPONSE TO CITY COMMENTS	BRC				

CALL BEFORE YOU DIG!
 "SUNSHINE STATE ONE-CALL CENTER"
 1-800-432-4770
 THE CONTRACTOR SHALL NOTIFY "SUNSHINE STATE ONE-CALL CENTER" AND ALL OTHER UTILITIES FOR LOCATION OF EXISTING FACILITIES PRIOR TO BEGINNING CONSTRUCTION.

ISSUE DATE: **JANUARY 27, 2022**

PUD MODIFICATION

AM ENGINEERING, LLC.

Civil Engineering | Land Surveying

8340 Consumer Court Sarasota, FL 34240
 Phone: (941) 377-9178 | www.amengll.com
 CA #33105 | LB #4334

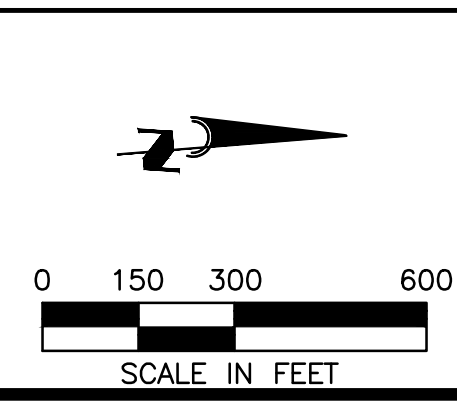

CLIENT: **NEAL COMMUNITIES OF SOUTHWEST FLORIDA, LLC**

PROJECT: **MILANO PUD**

TITLE: **MASTER SITE PLAN**

HORIZONTAL SCALE:	1" = 300'
VERTICAL SCALE:	N/A
PROJECT NUMBER:	NEAL0016PUD
SHEET NUMBER:	2

PROJECT ENGINEER:
 BOBBI R. CLAYBROOKE, PE
 DATE: _____
 FLORIDA P.E. No. 90804

© AM Engineering 2022. Sheet: 17-2722022-218.3.31. Rev. 11/16/2022. 4:13:48 PM. I:\Projects\2022\17-2722022-218\17-2722022-218.dwg. Mod. For Commercial Use (SJT) (AM)

Exhibit "B"

LEGAL DESCRIPTION (BY SURVEYOR)

COMMENCING AT THE NORTHEASTERLY CORNER OF TRACT 700, CIELO SUBDIVISION AS RECORDED IN PLAT BOOK 53, PAGE 288 OF SARASOTA COUNTY OFFICIAL RECORDS, THENCE SOUTH 00°00'06" WEST, A DISTANCE OF 55.04 FEET ALONG THE WEST RIGHT-OF-WAY LINE OF JACARANDA BOULEVARD TO THE POINT OF BEGINNING;
THENCE CONTINUE ALONG THE SAID RIGHT-OF-WAY SOUTH 00°00'06" WEST, 478.24 FEET;
THENCE DEPARTING SAID RIGHT-OF-WAY LINE, NORTH 89°14'10" WEST, 935.70 FEET;
THENCE NORTH 00°45'50" EAST, 72.60 FEET TO THE BEGINNING OF A CURVE TO THE LEFT HAVING A RADIUS OF 17.60 FEET AND WHOSE CHORD BEARS NORTH 11°25'30" WEST, 7.43 FEET;
THENCE NORTHERLY 7.49 FEET ALONG LAST SAID CURVE THROUGH A CENTRAL ANGLE OF 24°22'40", TO A REVERSE CURVE TO THE RIGHT HAVING A RADIUS OF 110.67 FEET AND WHOSE CHORD BEARS NORTH 11°23'08" WEST, 46.88 FEET;
THENCE NORTHERLY 47.24 FEET ALONG LAST SAID CURVE THROUGH A CENTRAL ANGLE OF 24°27'24";
THENCE NORTH 00°50'34" EAST, 130.16 FEET TO THE BEGINNING OF A CURVE TO THE LEFT HAVING A RADIUS OF 63.00 FEET AND WHOSE CHORD BEARS NORTH 11°31'26" WEST, 26.97 FEET;
THENCE NORTHERLY 27.18 FEET ALONG LAST SAID CURVE THROUGH A CENTRAL ANGLE OF 24°43'15", TO A REVERSE CURVE TO THE RIGHT HAVING A RADIUS OF 94.50 FEET AND WHOSE CHORD BEARS NORTH 11°58'28" WEST, 39.00 FEET;
THENCE NORTHERLY 39.29 FEET ALONG LAST SAID CURVE THROUGH A CENTRAL ANGLE OF 23°49'11";
THENCE NORTH 00°03'52" WEST, 159.00 FEET TO THE SOUTH LINE OF TRACT 700 OF SAID CIELO SUBDIVISION;
THENCE ALONG SAID SOUTH LINE, SOUTH 89°10'25" EAST, 957.24 FEET TO THE POINT OF BEGINNING.

CONTAINING 10.42 ACRES OR 453,722 SQUARE FEET, MORE OR LESS.